

OPERATING MANUAL

SPLIT TYPE SCROLL CONDENSING UNITS



Scan the QR code to view the Operating Manual on your tablet, mobile device, PC or laptop.

IMPORTANT!

READ BEFORE PROCEEDING

GENERAL OPERATING INSTRUCTION

This operating manual contains information necessary for installation, operation and maintenance of ICF Condensing Units manufactured by IBS Isıtma Soğutma Havalandırma Taahhüt San. ve Tic. A.Ş. This manual should be considered as an integral part of the unit and should be read by the technician who shall install and operate the cooling unit. This manual should be kept near the unit for application when needed.

Before installation and operation of the unit, please be sure to read the manual attentively. It is important for your safety to understand the concepts in this manual. Please, ask for technical support from authorized operating/service personnel. Conform to the instructions in this manual for safe and efficient use of your unit.

No cooling refrigerant and oil should be used other than those stated on label of the unit. The system should not be operated before completion of installation and gas charging stated on label of the device.

The manufacturer doesn't bear any responsibility due to losses and damages arising out of use, operation and applications not stated in this manual.

1- In Case of Danger

- Cut off main power supply.
- Contact with the nearest service.
- Don't apply anything to the device except for emergency interventions until the authorized service directed by our service centre comes.

2- Operations upon the Unit

- Installation, operation and maintenance should be performed by authorized operating/service personnel.
- While making any operation upon the unit, the mains electrical feeding should be cut off and the unit should wait for 10-15 minutes for cooling.

2- Features of Place of the Unit

- No dust.
- The floor should be rigid, sound and safe taking weight of the unit into consideration.
- Should be protected against flood and being left under snow
- Should be mounted in a place which doesn't prevent air induction and release and which is open to atmosphere.
- If installed in a closed area, it should absolutely have sufficient ventilation and there shouldn't be overheating.
- Be sure all measures about human health and environmental safety are taken

SAFETY WARNINGS

- Pay attention to the warnings to prevent damages to you and your goods.
- Try to understand safety warnings and take necessary precautions.
- Even if you have sufficient experience and knowledge, if you are not authorized, and if you don't have sufficient experience and knowledge even if you are authorized, never attend to adjustments, controls, installations and repair works.
- Control panel has fatal electrical voltage. Turn off the main power supply switch and label it with a work in progress sign before maintaining or repairing the equipment
- The units subject to high internal pressure during operation. The pipes and equipment containing pressurized gas are made of materials resistant to internal and external forces. Damages to the pipes and equipment during transport, installation and maintenance shall decrease safety of the unit. Don't allow any equipment to be damaged by external effects.
- All tests, adjustments and controls of the units have been performed. Don't change connections and adjustments of equipment during installation, maintenance and service.
- Electrical board and circuits are only for authorized personnel. Safety and protection precautions in these fields are valid as long as you don't change adjustments and connections. Direct or indirect contact with these fields may lead to danger. Don't touch any electrical cables, boards, tools and connections for any reason whatsoever. Keep away these fields and be sure that you are insulated.
- The units contain switches, thermic, contactors and similar mechanisms prepared to create a certain safety and precaution mechanism to allow for performance of functions in the units. Don't interfere with these mechanisms. Replace if they are damaged.
- Mechanical components are enclosed within a closed structure and are insulated from external access. Do not open protective covers or guards while the refrigeration system is in operation. If any cover has been opened, ensure it is properly closed before starting the refrigeration system. Exercise caution when touching these areas, even if the refrigeration system is not operating.
- Keep away from hot fields and surfaces of the refrigeration system. Don't remain close to these fields and don't contact directly or indirectly. Even if the refrigeration system isn't operating, wait for their cooling before touching these fields.
- There are warning labels on the units against the situations (stated or not stated in this manual). Don't touch or keep away the places with warning labels. Conform to the instructions on the labels.
- If the labels become illegible, replace them. You can find meanings of labels and which instructions shall be applied in the section titled "Meanings of Safety Labels" of this manual.

MEANINGS OF SAFETY LABELS



This “ATTENTION” sign is an important safety warning.
Warning! Risk of serious injury or death to person!
Caution! Danger which can lead to serious damages!
Notice! Risk of damage to equipment!



High voltage. Fatal Electrical Voltage. It is used to protect users and maintenance personnel from contacting parts or areas that carry electrical risk when the refrigeration system is operating or during maintenance. This label indicates the presence of an electrical hazard. Do not touch these areas without proper insulation protection or without disconnecting the power source. Do not use water, oil, or similar substances for cleaning purposes. Ensure that these areas remain properly insulated at all times. Do not damage the protective cap, cover, or insulation components.

CONTENTS

READ BEFORE PROCEEDING	2
GENERAL OPERATING INSTRUCTION	2
SAFETY WARNINGS	3
MEANINGS OF SAFETY LABELS	4
CONTENTS	5
NOMENCLATURE	6
PRODUCT NOMENCLATURE	6
PRODUCT FEATURES	7
STANDARD FEATURES FOR ALL LOW TO MEDIUM TEMPERATURE	
MODEL	7
OPTIONAL EQUIPMENT'S	7
SPECIFICATIONS	8
TABLE 1: CAPACITY DIAGRAM	8
TABLE 2: TECHNICAL DATA (MT AND LT TEMPERATURE TABLES)	9
TABLE 3: PERFORMANCE DATA: MEDIUM TEMPERATURE (R404A)	
.....	11
TABLE 4: PERFORMANCE DATA: LOW TEMPERATURE (R404A)	12
TABLE 5: PERFORMANCE DATA: MEDIUM	
TEMPERATURE(R448A/R449A)	13
TABLE 6: PERFORMANCE DATA: LOW	
TEMPERATURE(R448A/R449A)	14
TABLE 7: PERFORMANCE DATA: MEDIUM TEMPERATURE(R452A)	15
TABLE 8: PERFORMANCE DATA: LOW TEMPERATURE(R452A)	15
APPLICATION GUIDELINE	16
TABLE 9: OPERATING LIMITS	16
HEALTH AND SAFETY	17
GENERAL INFORMATION	17
BEFORE INSTALLATION	17
OFFLOADING AND LIFTING	17
DURING INSTALLATION AND SUBSEQUENT MAINTENANCE	17
INSTALLATION	18
UNIT LOCATION	18
INSTALLATION CLEARANCES	19
FIELD PIPING	19
PRESSURE TESTING	20
EVACUATION AND CHARGING	21
ELECTRICAL	22
RESERVE ROTATION PROTECTION AND VOLTAGE UNBALANCE	22
COMMISSIONING	23
PRE STARTUP CHECKS	23
RUNNING THE UNIT	23
SCROLL COMPRESSOR OPERATION	23
PRESSURE SWITCH SETTINGS	24
DUAL PRESSURE SWITCH (OPTIONAL EQUIPMENT)	25
FAN CONTROL SWITCH ACB-2UA 305W	25
FAN SPEED CONTROLLER XGE-4C (OPTIONAL EQUIPMENT)	25
CRANKCASE HEATERS	26
SIGNAL LAMPS (OPTIONAL EQUIPMENT)	26
SAFETY BRAKER (OPTIONAL EQUIPMENT)	26
UNITS WITH MICROCHANNEL CONDENSER	26
SYSTEM OPERATION	26
CYCLE DIAGRAM AND EQUIPMENT	27
MECHANICAL DIAGRAM WITH STANDARD EQUIPMENT'S	27
MECHANICAL DIAGRAM WITH OPTIONAL EQUIPMENT'S	27
SERVICE & MAINTENANCE	28
1. COMPRESSOR	28
2. TRADITIONAL FINNED & TUBE COIL CONDENSER AND FAN MOTOR	
& BLADE	28
3. MICROCHANNEL CONDENSER COIL	28
4. CONTROLS	29
5. POWER SUPPLY	29
6. REFRIGERANT CHARGE	29
7. COMPRESSOR REPLACEMENT	29
8. UNIT DECOMMISSIONING AND DISPOSAL	29
9. WARRANTY	29
F-GAS REQUIREMENT	30
WIRING DIAGRAMS	31
WITH STANDARD EQUIPMENT'S	31
WITH FULL OPTIONAL EQUIPMENT'S	33
CABIN	37
CABIN LISTS	37
OUTLINE DRAWINGS	41
TROUBLE SHOOTING	50
CERTIFICATES	53
2006/42/EC MACHINERY DIRECTIVE	53
ISO 9001:2015	54
CE DECLARATION OF CONFORMITY	55
FLUID GROUP 2 – ASSEMBLY PED MODULE B 2014/68/EU	56
FLUID GROUP 2 – ASSEMBLY PED MODULE D 2014/68/EU	57

NOMENCLATURE

PRODUCT NOMENCLATURE

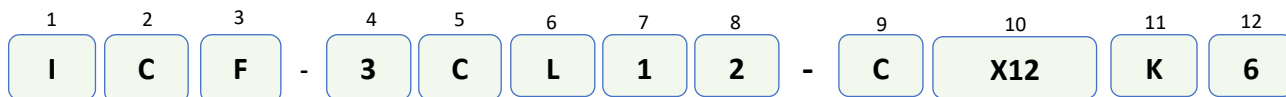

1. Manufacturer

IBS Cooling

I

2. Product Range

Condensing Unit

C

Central System

M

3. Cabin Type

Split

F

Industrial

E

Open Chassis

O

Midipack

S

Maxipack

V

4. Cabin/Condenser Code

Cabin/Condenser Code

X

5. Compressor Type

Scroll

C

Digital Scroll

D

Double Stage

K

Hermetic

H

Semi-Hermetic

S

Screw

V

6. Working Conditions

Medium Temperature

M

Low Temperature

L

Blast Freezing

F

Climate

B

7. Number of Compressors

Compressor Number

X

8. Number of Fans

Number of Fans

X

9. Compressor Brand

Bitzer

B

Copeland

C

Dorin

D

Maneurop

M

Danfoss

N

Embraco

E

Tecumseh

T

10. Cylinder Volume

Total Cylinder Volume

X

11. Refrigerant

R404A

Z

R407C

Z

R448A

K

R449A

L

R134a

Y

R410A

A

R452A

V

R717

N

12. Fan Speed

1400 rpm

4

660 rpm

6

890–990 rpm

8

Without Fan

0

PRODUCT FEATURES

Split Type hermetic condenser unit provides high efficiency and reliability for low to medium capacity cooling needs. It is ideal for display cases and cold rooms. Its compact design ensures quick and easy installation, minimizing maintenance requirements.

Standard features for all low to medium temperature model

1. Compressor (Copeland, Embraco, Danfoss)
2. Crankcase Heater
3. Air Cooled Condenser
4. Axial Fan
5. Liquid Receiver
6. Liquid Receiver Service Valve
7. Filter Drier
8. Solenoid Valve
9. Sight Glass
10. HP/LP Switch
11. Fan Pressure Switch
12. Integrated IP55 Electrical Panel

Optional Equipment's

1. Oil Separator (If added, the cabin dimensions can be change)
2. Suction Accumulator (If added, the cabin dimensions can be change)
3. Dual Pressure Switch
4. HP/LP Manometer
5. Fan Defrost Contactor
6. Acoustic Insulation for Compressor Compartment
7. Mechanical Fan Speed Controller
8. Safety Breaker
9. Signal Lamps

SPECIFICATIONS

Table 1: Capacity Diagram

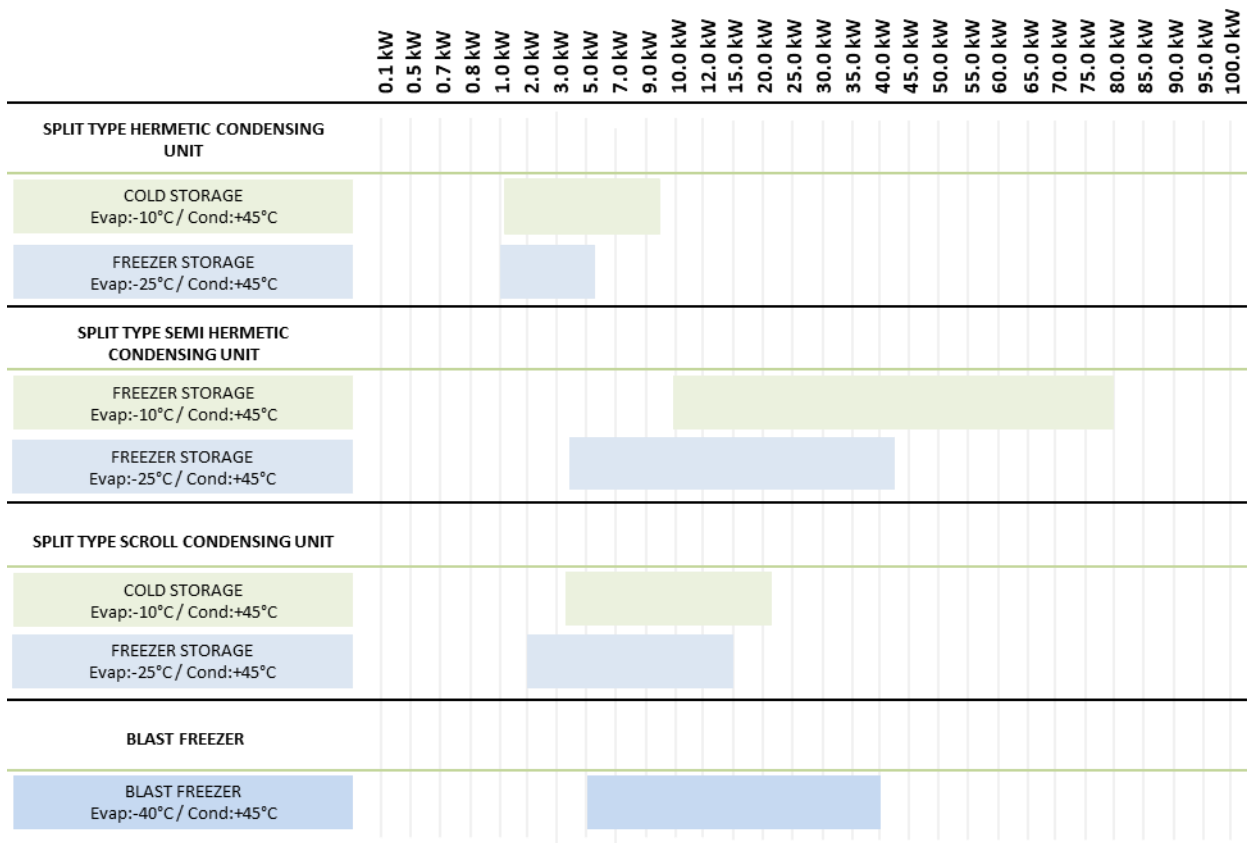

Indicator¹:

- NC^a: Nominal Current rated at condition (-10°C Te / +32°C Ta) for MT and (-35°C Te / +32°C Ta) for LT
- MCC^b: Maximum Continuous Current
- LRC^c: Locked Rotor Current
- SPL^d @10m: Sound Pressure Level measured 10m from unit, in an anechoic room rated at (-10°C Te / +32°C Ta) for MT and (-25°C Te / +32°C Ta) for LT. Alternative conditions may produce different results
- The recommended oil type for Copeland compressors is polyester, and the oil viscosity should be 32 mm²/s.
- The recommended oil type for Danfoss compressors is Danfoss 215PZ.

¹: The indicator belongs to Table 2.

Table 2: Technical Data (MT and LT Temperature Tables)

App.	Unit Model	C.O.P (Watt/W)			Compressor			Electrical Data						Liquid Receiver Volume	Airflow	Airflow	Connections		SPL @ 10m ^d	SPL @ 10m ^d	
		R404A	R448A / R449A	R452A	Type	Sw. Ept Volume (m³/h)	Oil Charge (Litres)	Compressor			Fan						Liquid	Gas			
								Nc ^a	MCC ^b	LRC ^c	No	900									1400
												Total FLC	No						Total FLC	No	
(A)	(A)	(A)	(A)	(A)	(A)	(A)	(A)	(A)	(A)	(A)	(A)	(A)	(A)	(A)	(A)	(A)	(A)	(A)	(A)		
Medium Temperature	ICF-1CM11-C5.9	1,82	1,90	-	ZB15KCE	5,92	0,74	-	4,9	26	1	0,55	1	0,73	4	2608	2700	10	18	39	48
	ICF-1CM11-C6.8	1,86	2,08	-	ZB19KCE	6,83	1,12	-	6,5	32	1	0,8	1	0,73	4	3469	2436	10	18	43	48
	ICF-3CM11-C8.6	2,01	2,08	-	ZB21KCE	8,61	1,24	-	7,2	40	1	1,18	1	1,1	5	4322	4430	10	22	40	52
	ICF-3CM11-CX10	1,99	2,05	-	ZB26KCE	9,94	1,12	-	8,9	46	1	1,18	1	1,1	5	3892	4430	10	22	40	52
	ICF-3CM11-CX12	2,01	2,15	-	ZB29KCE	11,4	1,45	-	10	50	1	1,18	1	3	6	3892	5915	12	28	40	54
	ICF-4CM12-CX14	2,03	2,16	-	ZB38KCE	14,4	1,9	-	12,8	66	2	2,36	2	2,2	7	7386	8061	12	28	43	55
	ICF-4CM12-CX17	2,09	2,23	-	ZB45KCE	17,1	1,9	-	13,1	74	2	2,36	2	6	8	6593	10324	12	28	43	57
	ICF-4CM12-CX19	2,11	2,23	-	ZB48KCE	18,8	1,77	-	14	101	2	2,36	2	6	10	7386	9230	12	28	43	57
	ICF-5CM12-CX21	2,25	2,29	-	ZB57KCE	21,4	1,89	-	15,9	102	2	2,36	2	6	12	6692	10255	12	28	43	57
	ICF-5CM12-CX29	2,20	2,32	-	ZB76KCE	29,1	3,25	-	20,4	118	4	4,72	2	6	18	14772	9436	16	35	46	57
	ICF-7CM14-CX36	2,14	2,16	-	ZB95KCE	36,4	3,25	-	28,2	140	4	4,72	4	12	21	14771	22563	18	42	46	60
	ICF-1CM11-N5.9	1,89	1,91	1,97	MLZ015	5,9	1,06	4,5	7	30	1	0,55	1	0,73	4	2608	2700	10	18	39	48
	ICF-1CM11-N7.6	2,07	1,99	1,99	MLZ019	7,6	1,06	6,1	9,5	45	1	0,8	1	0,73	4	3469	2436	10	18	43	48
	ICF-3CM11-N8.0	2,08	1,97	2,02	MLZ021	8	1,14	6,1	9,5	45	1	1,18	1	1,1	5	4322	4430	10	22	40	52
	ICF-3CM11-N9.9	2,00	1,97	2,02	MLZ026	9,9	1,14	6,40	10	45	1	1,18	1	1,1	5	3892	4430	10	22	40	52
	ICF-3CM11-NX12	2,11	2,08	2,10	MLZ030	12	1,73	8,30	13	60	1	1,18	1	3	6	3892	5915	12	28	40	54
	ICF-4CM12-NX14	2,19	2,14	2,10	MLZ038	14	1,73	9,60	15	70	2	2,36	2	2,2	7	7386	8061	12	28	43	55
	ICF-4CM12-NX17	2,09	2,11	2,09	MLZ045	17	1,73	9,6	15	82	2	2,36	2	6	8	6593	10324	12	28	43	57
	ICF-4CM12-NX19	2,09	2,06	2,12	MLZ048	19	1,73	10,3	16	87	2	2,36	2	6	10	7386	9230	12	28	43	57
	ICF-5CM12-NX22	2,13	2,19	2,19	MLZ058	22	2,66	12,80	20	95	2	2,36	2	6	12	6692	10255	12	28	43	57
	ICF-5CM12-NX28	2,18	1,99	2,04	MLZ076	28	2,66	19,20	25	140	4	4,72	2	6	18	14772	9436	16	35	46	57
	ICF-1CM11-E6.0	2,05	2,05	1,91	SE6015GS	5,8	1,4	3,1	5,2	22	1	0,55	1	0,73	4	2608	2436	10	18	39	48
	ICF-3CM11-E7.0	2,17	2,17	2,02	SE6018GS	7,3	1,4	4,4	6,4	45	1	0,8	1	0,73	5	3469	3452	10	22	43	48
	ICF-3CM11-E8.0	2,23	2,23	2,08	SE6021GS	8,1	1,4	4,6	6,9	45	1	1,18	1	0,73	5	4322	3452	10	22	40	48
	ICF-3CM11-EX12	2,30	2,30	2,14	SE6030GS	11,8	1,4	6,4	10,3	60	2	1,1	1	3	6	4513	5401	12	28	42	54
	ICF-4CM12-EX14	2,35	2,35	2,19	SE6036GS	14,5	1,4	7,1	12,2	60	2	2,36	2	1,46	7	7386	6461	12	28	43	51
	ICF-4CM12-EX17	2,35	2,35	2,18	SE6043GS	17,1	1,4	8,2	14,3	65	2	2,36	2	6	8	6593	10324	12	28	43	57
	ICF-4CM12-EX20	2,35	2,35	2,18	SE6053GS	20,1	2,7	10,9	17	117	2	2,36	2	6	12	6692	9230	12	28	43	57
	ICF-5CM12-EX21	2,35	2,35	2,18	SE6056GS	21,4	2,7	11,2	18	117	2	2,36	2	6	14	6692	10255	12	35	43	57
	ICF-5CM12-EX25	2,35	2,35	2,18	SE6067GS	25,3	2,7	12,6	21	117	4	4,72	2	6	16	14772	9436	12	35	46	57
	ICF-6CM14-EX29	2,35	2,35	2,18	SE6078GS	29,1	2,7	13,7	24	121	4	4,72	4	4,4	18	16160	16123	16	35	46	60
	ICF-6CM14-EX33	2,37	2,37	2,21	SE6085GS	32,9	2,7	14,5	27	121	4	4,72	4	12	21	16160	20648	18	42	46	60
	ICF-7CM14-EX34	2,37	2,37	2,21	SE6089GS	34,3	2,7	15,1	27,6	121	4	4,72	4	12	21	14771	22563	18	42	46	60

App.	Unit Model	C.O.P (Watt/W)			Compressor			Electrical Data						Liquid Receiver Volume	Airflow	Airflow	Connections		SPL @ 10m ^d	SPL @ 10m ^d		
		R404A	R448A/ R449A	R452A	Type	Sw. Ept Volume (m ³ /h)	Oil Charge (Litres)	Compressor			Fan						Liquid	Gas			900 Rpm	1400 Rpm
								Nc ^a	MCC ^b	LRC ^c	No	Total FLC	No									
								(A)	(A)	(A)	(A)	(A)	(A)						(A)	(A)	(Litres)	(m ³ /h)
Low Temperature	ICF-1CL11-C8.0	1,36	1,43	-	ZF09K4E-TFD	8,03	1,5	-	6	40	1	0,55	1	0,73	3	2608	2436	10	22	31	48	
	ICF-3CL11-C9.9	1,40	1,34	-	ZF11K4E-TFD	9,95	1,5	-	7,1	46	1	1,18	1	0,73	4	4322	3452	10	22	40	48	
	ICF-3CL11-CX12	1,45	1,44	-	ZF13K4E-TFD	11,7	1,9	-	8	52	1	1,18	1	1,1	4	4322	4430	10	22	40	52	
	ICF-3CL11-CX15	1,33	1,32	-	ZF15K4E-TFD	14,4	1,9	-	10	64	1	1,18	1	3	5	3892	5915	10	28	40	54	
	ICF-3CL11-CX17	1,37	1,33	-	ZF18K4E-TFD	17,1	1,9	-	12,5	74	2	1,6	1	3	8	5952	5401	12	28	46	54	
	ICF-4CL12-CX21	1,56	1,52	-	ZF25K5E-TFD	21,4	1,89	-	16	102	2	2,36	2	2,2	10	7386	8061	12	35	43	55	
	ICF-4CL12-CX29	1,55	1,51	-	ZF34K5E-TFD	29,1	3,37	-	25	100	2	2,36	2	6	14	7386	10324	12	35	43	57	
	ICF-5CL12-CX35	1,53	1,55	-	ZF41K5E-TFD	35,3	3,37	-	29	118	4	3,2	2	6	16	11903	10255	16	42	49	57	
	ICF-5CL12-CX43	1,57	1,52	-	ZF49K5E-TFD	42,4	3,37	-	30	139	4	4,72	2	6	18	14772	9436	16	42	46	57	
	ICF-3CL11-NX12	1,38	2,023	2,363	LLZ013T4	12	1,62	8	12	62	1	1,18	1	1,1	4	4322	4430	10	22	40	52	
	ICF-3CL11-NX15	1,41	2,052	2,31	LLZ015T4	15	1,62	9,6	15	88,5	1	1,18	1	3	5	3892	5915	10	28	40	54	
	ICF-3CL11-NX17	1,46	2,11	2,355	LLZ018T4	17	1,62	10,00	15	90	2	1,6	1	3	8	5952	5401	12	28	46	54	
	ICF-1CL11-E6.0	1,27	1,307	1,275	SE2006GS	5,8	1,4	2,20	3,8	22	1	0,55	1	0,7	2	1877	2268	10	16	31	42	
	ICF-1CL11-E7.0	1,28	1,317	1,285	SE2008GS	7,3	1,4	2,60	4,4	22	1	0,55	1	0,73	3	2608	2700	10	22	31	48	
	ICF-1CL11-E8.0	1,29	1,33	1,298	SE2010GS	8,1	1,4	4,00	5,8	45	1	0,55	1	0,73	3	2608	2436	10	22	31	48	
	ICF-3CL11-EX12	1,41	1,458	1,423	SE2014GS	11,8	1,4	5,60	8,8	60	1	1,18	1	1,1	4	4322	4430	10	22	40	52	
	ICF-3CL11-EX14	1,46	1,507	1,47	SE2017GS	14,5	1,4	5,90	10,3	60	1	1,18	1	3	5	3892	5915	10	28	40	54	
ICF-3CL11-EX17	1,47	1,518	1,481	SE2020GS	17,1	1,4	6,60	12,1	60	2	1,1	1	3	8	4513	5401	12	28	34	54		

Table 3: Performance Data: Medium Temperature (R404A)

R404A					Cooling Capacity(Watts)						Power Input (Watts)					
Unit Model	Compressor	HP	Tc \ Te		-20	-15	-10	-5	0	5	-20	-15	-10	-5	0	5
			Tc	Te												
Copeland Series	ICF-1CM11-C5.9	ZB15KCE	1,5	45	2,13	2,69	3,32	4,04	4,85	5,77	1,94	1,88	1,82	1,76	1,72	1,69
	ICF-1CM11-C6.8	ZB19KCE	2,5	45	2,62	3,21	3,90	4,70	5,62	6,67	2,11	2,11	2,10	2,09	2,07	2,06
	ICF-3CM11-C8.6	ZB21KCE	3	45	3,40	4,16	5,05	6,07	7,24	8,57	2,52	2,52	2,51	2,50	2,48	2,46
	ICF-3CM11-CX10	ZB26KCE	3,5	45	3,95	4,82	5,84	7,02	8,38	9,96	2,96	2,95	2,94	2,93	2,91	2,89
	ICF-3CM11-CX12	ZB29KCE	4	45	4,53	5,50	6,62	7,90	9,36	11,00	3,27	3,28	3,29	3,30	3,29	3,28
	ICF-4CM12-CX14	ZB38KCE	5	45	5,74	7,03	8,53	10,25	12,30	14,55	4,19	4,20	4,20	4,20	4,19	4,16
	ICF-4CM12-CX17	ZB45KCE	6	45	6,77	8,29	10,05	12,10	14,40	17,10	4,81	4,82	4,81	4,79	4,76	4,72
	ICF-4CM12-CX19	ZB48KCE	7	45	7,84	9,60	11,65	13,95	16,65	19,75	5,53	5,53	5,52	5,50	5,46	5,42
	ICF-5CM12-CX21	ZB57KCE	7,5	45	9,04	10,95	13,20	15,75	18,70	22,10	5,39	5,64	5,86	6,06	6,22	6,36
	ICF-5CM12-CX29	ZB76KCE	10	45	12,00	14,85	18,10	21,80	25,90	30,60	8,09	8,14	8,21	8,28	8,36	8,40
	ICF-7CM14-CX36	ZB95KCE	13	45	-	18,15	22,40	27,00	32,10	37,80	-	10,40	10,45	10,50	10,55	10,60
Danfoss Series	ICF-1CM11-N5.9	MLZ015	1,5	45	2,12	2,68	3,30	4,00	4,80	5,71	1,83	1,79	1,75	1,71	1,68	1,66
	ICF-1CM11-N7.6	MLZ019	2,5	45	3,00	3,68	4,45	5,33	6,35	7,53	2,13	2,15	2,16	2,14	2,13	2,11
	ICF-3CM11-N8.0	MLZ021	3	45	3,19	3,90	4,72	5,66	6,75	8,00	2,25	2,27	2,27	2,27	2,26	2,24
	ICF-3CM11-N9.9	MLZ026	3,5	45	3,90	4,78	5,80	6,99	8,37	9,96	2,89	2,90	2,90	2,90	2,90	2,89
	ICF-3CM11-NX12	MLZ030	4	45	4,72	5,81	7,07	8,54	10,21	12,13	3,34	3,35	3,35	3,35	3,35	3,34
	ICF-4CM12-NX14	MLZ038	5	45	5,68	6,97	8,45	10,15	12,11	14,35	3,88	3,87	3,86	3,85	3,87	3,89
	ICF-4CM12-NX17	MLZ045	6	45	6,77	8,38	10,24	12,38	14,83	17,62	4,90	4,90	4,89	4,89	4,89	4,89
	ICF-4CM12-NX19	MLZ048	7	45	7,39	9,19	11,24	13,57	16,22	19,21	5,34	5,36	5,38	5,39	5,41	5,42
	ICF-5CM12-NX22	MLZ058	7,5	45	8,34	10,52	12,98	15,74	18,85	22,35	6,01	6,04	6,08	6,12	6,17	6,22
	ICF-5CM12-NX28	MLZ076	10	45	12,04	14,48	17,32	20,65	24,58	29,22	7,83	7,86	7,93	8,01	8,09	8,17
Embraco Series	ICF-1CM11-E6.0	SE6015GS	2	45	2,38	2,93	3,57	4,30	5,16	6,16	1,55	1,64	1,74	1,83	1,92	2,00
	ICF-3CM11-E7.0	SE6018GS	2,5	45	2,84	3,50	4,26	5,13	6,16	7,35	1,75	1,86	1,96	2,06	2,17	2,26
	ICF-3CM11-E8.0	SE6021GS	3	45	3,23	3,99	4,85	5,85	7,01	8,37	1,94	2,06	2,17	2,29	2,40	2,51
	ICF-3CM11-EX12	SE6030GS	4	45	4,62	5,70	6,93	8,36	10,02	11,96	2,69	2,85	3,01	3,17	3,33	3,48
	ICF-4CM12-EX14	SE6036GS	5	45	5,68	6,00	8,51	10,27	12,31	14,70	3,24	3,43	3,63	3,82	4,01	4,19
	ICF-4CM12-EX17	SE6043GS	6	45	6,75	8,32	10,11	12,20	14,63	17,46	3,85	4,08	4,31	4,54	4,76	4,98
	ICF-4CM12-EX20	SE6053GS	7	45	8,18	10,08	12,26	14,78	17,73	21,16	4,45	4,94	5,22	5,50	5,77	6,03
	ICF-5CM12-EX21	SE6056GS	8	45	8,61	10,62	12,91	15,57	18,67	22,29	4,92	5,21	5,50	5,79	6,08	6,35
	ICF-5CM12-EX25	SE6067GS	9	45	10,58	13,05	15,86	19,13	22,94	27,39	6,04	6,40	6,76	7,12	7,47	7,80
	ICF-6CM14-EX29	SE6078GS	10	45	11,93	14,70	17,88	21,57	25,86	30,87	6,81	7,21	7,62	8,02	8,42	8,80
	ICF-6CM14-EX33	SE6085GS	12	45	13,05	16,09	19,56	23,59	28,29	33,77	7,38	7,81	8,25	8,69	9,12	9,53
ICF-7CM14-EX34	SE6089GS	13	45	13,72	16,92	20,57	24,81	29,75	35,52	7,76	8,21	8,68	9,14	9,59	10,02	

Tc: Condensing Temperature(°C)

Te: Evaporating Temperature (°C)

Rating Condition: EN12900 RGT 20 °C

All duties are +/- 10%

Table 4: Performance Data: Low Temperature (R404A)

R404A					Cooling Capacity (Watts)					Power Input (Watts)				
	Unit Model	Compressor	HP	Tc Te	-35	-30	-25	-20	-15	-35	-30	-25	-20	-15
Copeland Series	ICF-1CL11-C8.0	ZF09K4E-TFD	3	45	1,82	2,25	2,76	3,35	4,04	1,96	1,99	2,03	2,09	2,17
	ICF-3CL11-C9.9	ZF11K4E-TFD	3,5	45	2,29	2,83	3,45	4,17	5,02	2,35	2,40	2,46	2,55	2,65
	ICF-3CL11-CX12	ZF13K4E-TFD	4	45	2,59	3,22	3,97	4,85	5,88	2,58	2,65	2,74	2,84	2,95
	ICF-3CL11-CX15	ZF15K4E-TFD	5	45	3,18	3,96	4,87	5,93	7,18	3,33	3,49	3,65	3,82	3,99
	ICF-3CL11-CX17	ZF18K4E-TFD	6	45	3,70	4,68	5,78	7,04	8,50	4,11	4,16	4,23	4,33	4,45
	ICF-4CL12-CX21	ZF25K5E-TFD	7,5	45	4,77	5,93	7,29	8,89	10,80	4,08	4,38	4,68	4,98	5,28
	ICF-4CL12-CX29	ZF34K5E-TFD	10	45	6,25	7,84	9,68	11,80	14,30	5,55	5,88	6,24	6,61	7,00
	ICF-5CL12-CX35	ZF41K5E-TFD	12	45	7,83	9,74	12,00	14,60	17,70	6,89	7,37	7,85	8,33	8,81
	ICF-5CL12-CX43	ZF49K5E-TFD	15	45	9,37	11,70	14,40	17,60	21,40	8,33	8,73	9,20	9,74	10,30
Danfoss Series	ICF-3CL11-NX12	LLZ013T4	4	45	2,58	3,25	4,03	4,92	5,94	2,53	2,73	2,93	3,12	3,30
	ICF-3CL11-NX15	LLZ015T4	5	45	3,15	3,95	4,89	6,00	7,30	2,95	3,20	3,46	3,73	4,00
	ICF-3CL11-NX17	LLZ018T4	6	45	3,70	4,64	5,75	7,05	8,58	3,35	3,63	3,93	4,24	4,54
Embraco Series	ICF-1CL11-E6.0	SE2006GS	2	45	1,17	1,45	1,80	2,20	2,67	1,28	1,35	1,42	1,49	1,57
	ICF-1CL11-E7.0	SE2008GS	2,5	45	1,49	1,86	2,30	2,81	3,40	1,62	1,71	1,80	1,89	1,99
	ICF-1CL11-E8.0	SE2010GS	3	45	1,75	2,18	2,70	3,30	4,00	1,89	1,99	2,09	2,20	2,31
	ICF-3CL11-EX12	SE2014GS	4	45	2,65	3,30	4,08	4,99	6,05	2,61	2,74	2,89	3,04	3,19
	ICF-3CL11-EX14	SE2017GS	5	45	3,14	3,92	4,84	5,92	7,18	2,99	3,15	3,31	3,49	3,67
	ICF-3CL11-EX17	SE2020GS	6	45	3,68	4,59	5,67	6,94	8,41	3,48	3,66	3,85	4,05	4,26

Tc: Condensing Temperature(°C)

Te: Evaporating Temperature (°C)

Rating Condition: EN12900 RGT 20 °C

All duties are +/- 10%

Table 5: Performance Data: Medium Temperature(R448A/R449A)

R448A/R449A					Cooling Capacity(Watts)						Power Input (Watts)					
Unit Model	Compressor	HP	Tc \ Te		-20	-15	-10	-5	0	5	-20	-15	-10	-5	0	5
			Tc	Te												
Copeland Series	ICF-1CM11-C5.9	ZB15KCE	1,5	45	-	2,60	3,27	4,03	4,92	5,94	-	1,76	1,72	1,70	1,67	1,66
	ICF-1CM11-C6.8	ZB19KCE	2,5	45	-	3,08	3,83	4,72	5,76	6,93	-	1,85	1,84	1,83	1,84	1,86
	ICF-3CM11-C8.6	ZB21KCE	3	45	-	3,93	4,87	5,96	7,22	8,67	-	2,34	2,34	2,35	2,37	2,39
	ICF-3CM11-CX10	ZB26KCE	3,5	45	-	4,43	5,51	6,77	8,22	9,90	-	2,68	2,69	2,70	2,71	2,73
	ICF-3CM11-CX12	ZB29KCE	4	45	-	5,23	6,43	7,83	9,48	11,40	-	2,97	2,99	3,01	3,03	3,05
	ICF-4CM12-CX14	ZB38KCE	5	45	-	6,69	8,34	10,20	12,35	14,85	-	3,88	3,87	3,87	3,88	3,90
	ICF-4CM12-CX17	ZB45KCE	6	45	-	7,83	9,77	11,95	14,45	17,40	-	4,39	4,38	4,38	4,39	4,42
	ICF-4CM12-CX19	ZB48KCE	7	45	-	8,78	10,85	13,20	16,00	19,25	-	4,87	4,87	4,88	4,90	4,94
	ICF-5CM12-CX21	ZB57KCE	7,5	45	-	10,20	12,50	15,15	18,25	21,90	-	5,25	5,47	5,65	5,76	5,85
	ICF-5CM12-CX29	ZB76KCE	10	45	-	13,75	17,30	21,30	25,80	30,90	-	7,42	7,46	7,52	7,61	7,74
	ICF-7CM14-CX36	ZB95KCE	13	45	-	16,45	21,10	26,00	31,50	37,70	-	9,73	9,75	9,82	9,93	10,10
Danfoss Series	ICF-1CM11-N5.9	MLZ015	1,5	45	-	2,58	3,22	3,96	4,83	5,83	-	1,70	1,68	1,69	1,70	1,72
	ICF-1CM11-N7.6	MLZ019	2,5	45	-	3,39	4,21	5,16	6,27	7,55	-	2,07	2,11	2,15	2,17	2,19
	ICF-3CM11-N8.0	MLZ021	3	45	-	3,54	4,40	5,42	6,60	7,96	-	2,24	2,23	2,23	2,24	2,25
	ICF-3CM11-N9.9	MLZ026	3,5	45	-	4,36	5,47	6,75	8,22	9,91	-	2,76	2,78	2,79	2,80	2,80
	ICF-3CM11-NX12	MLZ030	4	45	-	5,30	6,58	8,08	9,83	11,86	-	3,20	3,17	3,17	3,20	3,24
	ICF-4CM12-NX14	MLZ038	5	45	-	6,29	7,78	9,53	11,57	13,93	-	3,66	3,64	3,66	3,72	3,81
	ICF-4CM12-NX17	MLZ045	6	45	-	7,77	9,66	11,87	14,43	17,40	-	4,59	4,58	4,58	4,59	4,63
	ICF-4CM12-NX19	MLZ048	7	45	-	8,40	10,42	12,79	15,56	18,76	-	5,14	5,06	5,03	5,02	5,04
	ICF-5CM12-NX22	MLZ058	7,5	45	-	9,84	12,20	14,97	18,20	21,94	-	5,56	5,57	5,59	5,63	5,69
	ICF-5CM12-NX28	MLZ076	10	45	-	12,01	15,17	18,88	23,21	28,23	-	7,71	7,61	7,56	7,56	7,63
Embraco Series	ICF-1CM11-E6.0	SE6015GS	2	45	2,38	2,93	3,57	4,30	5,16	6,16	1,55	1,64	1,74	1,83	1,92	2,00
	ICF-3CM11-E7.0	SE6018GS	2,5	45	2,84	3,50	4,26	5,13	6,16	7,35	1,75	1,86	1,96	2,06	2,17	2,26
	ICF-3CM11-E8.0	SE6021GS	3	45	3,23	3,99	4,85	5,85	7,01	8,37	1,94	2,06	2,17	2,29	2,40	2,51
	ICF-3CM11-EX12	SE6030GS	4	45	4,62	5,70	6,93	8,36	10,02	11,96	2,69	2,85	3,01	3,17	3,33	3,48
	ICF-4CM12-EX14	SE6036GS	5	45	5,68	7,00	8,51	10,27	12,31	14,70	3,24	3,43	3,63	3,82	4,01	4,19
	ICF-4CM12-EX17	SE6043GS	6	45	6,75	8,32	10,11	12,20	14,63	17,46	3,85	4,08	4,31	4,54	4,76	4,98
	ICF-4CM12-EX20	SE6053GS	7	45	8,18	10,08	12,26	14,78	17,73	21,16	4,67	4,94	5,22	5,50	5,77	6,03
	ICF-5CM12-EX21	SE6056GS	8	45	8,61	10,62	12,91	15,57	18,67	22,29	4,92	5,21	5,50	5,79	6,08	6,35
	ICF-5CM12-EX25	SE6067GS	9	45	10,58	13,05	15,86	19,13	22,94	27,39	6,04	6,40	6,76	7,12	7,47	7,80
	ICF-6CM14-EX29	SE6078GS	10	45	11,93	14,70	17,88	21,57	25,86	30,87	6,81	7,21	7,62	8,02	8,42	8,80
	ICF-6CM14-EX33	SE6085GS	12	45	13,05	16,09	19,56	23,59	28,29	33,77	7,38	7,81	8,25	8,69	9,12	9,53
ICF-7CM14-EX34	SE6089GS	13	45	13,72	16,92	20,57	24,81	29,75	35,52	7,76	8,21	8,68	9,14	9,59	10,02	

Tc: Condensing Temperature(°C)

Te: Evaporating Temperature (°C)

Rating Condition: EN12900 RGT 20 °C

All duties are +/- 10%

Table 6: Performance Data: Low Temperature(R448A/R449A)

R448A/R449A					Cooling Capacity (Watts)					Power Input (Watts)				
	Unit Model	Compressor	HP	Tc Te	-35	-30	-25	-20	-15	-35	-30	-25	-20	-15
Copeland Series	ICF-1CL11-C8.0	ZF09K4E-TFD	3	45	1,58	2,00	2,50	3,09	3,79	1,63	1,68	1,75	1,82	1,92
	ICF-3CL11-C9.9	ZF11K4E-TFD	3,5	45	1,96	2,49	3,10	3,82	4,66	2,22	2,26	2,31	2,39	2,48
	ICF-3CL11-CX12	ZF13K4E-TFD	4	45	2,29	2,91	3,64	4,52	5,55	2,35	2,44	2,53	2,62	2,74
	ICF-3CL11-CX15	ZF15K4E-TFD	5	45	2,82	3,56	4,45	5,50	6,73	3,14	3,24	3,36	3,50	3,65
	ICF-3CL11-CX17	ZF18K4E-TFD	6	45	3,38	4,36	5,49	6,79	8,31	4,29	4,18	4,14	4,16	4,23
	ICF-4CL12-CX21	ZF25K5E-TFD	7,5	45	4,36	5,53	6,93	8,58	10,55	4,23	4,39	4,57	4,79	5,03
	ICF-4CL12-CX29	ZF34K5E-TFD	10	45	5,71	7,32	9,20	11,40	14,00	5,76	5,89	6,09	6,35	6,67
	ICF-5CL12-CX35	ZF41K5E-TFD	12	45	7,00	8,88	11,10	13,70	16,75	6,45	6,76	7,14	7,62	8,22
	ICF-5CL12-CX43	ZF49K5E-TFD	15	45	8,56	10,90	13,70	17,00	20,90	8,65	8,75	8,99	9,35	9,82
Danfoss Series	ICF-3CL11-NX12	LLZ013T4	4	45	2,34	3,08	3,97	5,03	6,29	1,67	1,82	1,96	2,09	2,20
	ICF-3CL11-NX15	LLZ015T4	5	45	2,98	3,91	5,03	6,37	7,95	2,10	2,27	2,45	2,62	2,75
	ICF-3CL11-NX17	LLZ018T4	6	45	3,52	4,59	5,89	7,45	9,28	2,35	2,57	2,79	3,00	3,17
Embraco Series	ICF-1CL11-E6.0	SE2006GS	2	45	1,12	1,39	1,71	2,09	2,55	1,19	1,24	1,31	1,38	1,45
	ICF-1CL11-E7.0	SE2008GS	2,5	45	1,43	1,77	2,18	2,67	3,26	1,50	1,58	1,66	1,74	1,83
	ICF-1CL11-E8.0	SE2010GS	3	45	1,68	2,08	2,56	3,14	3,83	1,75	1,83	1,93	2,03	2,13
	ICF-3CL11-EX12	SE2014GS	4	45	2,54	3,15	3,88	4,75	5,79	2,41	2,53	2,66	2,80	2,94
	ICF-3CL11-EX14	SE2017GS	5	45	3,02	3,73	4,60	5,63	6,87	2,77	2,90	3,05	3,21	3,38
	ICF-3CL11-EX17	SE2020GS	6	45	3,53	4,38	5,39	6,60	8,05	3,22	3,37	3,55	3,73	3,93

Tc: Condensing Temperature(°C)

Te: Evaporating Temperature (°C)

Rating Condition: EN12900 RGT 20 °C

All duties are +/- 10%

Table 7: Performance Data: Medium Temperature(R452A)

R452A					Cooling Capacity(Watts)						Power Input (Watts)					
	Unit Model	Compressor	HP	Tc	-20	-15	-10	-5	0	5	-20	-15	-10	-5	0	5
				Te												
Danfoss Series	ICF-1CM11-N5.9	MLZ015	1,5	45	2,24	2,75	3,36	4,07	4,89	5,85	1,66	1,69	1,71	1,72	1,72	1,72
	ICF-1CM11-N7.6	MLZ019	2,5	45	2,86	3,53	4,32	5,23	6,28	7,50	2,14	2,15	2,17	2,18	2,19	2,20
	ICF-3CM11-N8.0	MLZ021	3	45	3,00	3,73	4,59	5,58	6,72	8,05	2,22	2,25	2,27	2,28	2,28	2,27
	ICF-3CM11-N9.9	MLZ026	3,5	45	3,73	4,63	5,68	6,90	8,31	9,93	2,81	2,81	2,81	2,82	2,82	2,83
	ICF-3CM11-NX12	MLZ030	4	45	4,58	5,63	6,87	8,34	10,06	12,07	3,22	3,25	3,27	3,28	3,29	3,29
	ICF-4CM12-NX14	MLZ038	5	45	5,26	6,53	8,01	9,73	11,72	14,00	3,75	3,78	3,81	3,84	3,88	3,92
	ICF-4CM12-NX17	MLZ045	6	45	6,68	8,23	10,05	12,18	14,66	17,51	4,77	4,78	4,81	4,84	4,87	4,91
	ICF-4CM12-NX19	MLZ048	7	45	7,18	8,93	10,98	13,38	16,16	19,36	5,19	5,17	5,17	5,19	5,21	5,24
	ICF-5CM12-NX22	MLZ058	7,5	45	8,39	10,47	12,90	15,72	18,97	22,72	5,73	5,82	5,89	5,94	5,99	6,04
	ICF-5CM12-NX28	MLZ076	10	45	10,32	13,05	16,17	19,76	23,85	28,52	7,84	7,90	7,94	7,97	8,00	8,05
Embraco Series	ICF-1CM11-E6.0	SE6015GS	2	45	2,34	2,90	3,56	4,32	5,21	6,22	1,66	1,76	1,86	1,96	2,06	2,14
	ICF-3CM11-E7.0	SE6018GS	2,5	45	2,79	3,47	4,25	5,16	6,21	7,43	1,88	1,99	2,10	2,22	2,32	2,42
	ICF-3CM11-E8.0	SE6021GS	3	45	3,18	3,95	4,84	5,88	7,08	8,46	2,08	2,21	2,33	2,46	2,57	2,68
	ICF-3CM11-EX12	SE6030GS	4	45	4,54	5,64	6,92	8,40	10,12	12,10	2,88	3,06	3,23	3,40	3,57	3,72
	ICF-4CM12-EX14	SE6036GS	5	45	5,58	6,93	8,50	10,32	12,43	14,86	3,47	3,68	3,89	4,10	4,30	4,47
	ICF-4CM12-EX17	SE6043GS	6	45	6,63	8,24	10,10	12,26	14,77	17,65	4,12	4,37	4,62	4,87	5,10	5,32
	ICF-4CM12-EX20	SE6053GS	7	45	8,03	9,98	12,24	14,86	17,90	21,39	5,00	5,30	5,60	5,90	6,18	6,44
	ICF-5CM12-EX21	SE6056GS	8	45	8,46	10,51	12,89	15,65	18,85	22,54	5,27	5,58	5,90	6,22	6,51	6,79
	ICF-5CM12-EX25	SE6067GS	9	45	10,39	12,92	15,84	19,23	23,16	27,69	6,47	6,86	7,25	7,64	8,00	8,34
	ICF-6CM14-EX29	SE6078GS	10	45	11,71	14,56	17,86	21,68	26,11	31,21	7,29	7,73	8,17	8,61	9,02	9,40
	ICF-6CM14-EX33	SE6085GS	12	45	12,82	15,93	19,54	23,72	28,56	34,15	7,90	8,37	8,85	9,33	9,77	10,18
	ICF-7CM14-EX34	SE6089GS	13	45	13,48	16,75	20,54	24,94	30,04	35,91	8,31	8,80	9,31	9,81	10,28	10,70

Table 8: Performance Data: Low Temperature(R452A)

R452A					Cooling Capacity (Watts)					Power Input (Watts)				
	Unit Model	Compressor	HP	Tc	-35	-30	-25	-20	-15	-35	-30	-25	-20	-15
				Te										
Danfoss Series	ICF-3CL11-NX12	LLZ013T4	4	45	2,95	3,77	4,77	5,96	7,36	1,75	1,89	2,02	2,13	2,25
	ICF-3CL11-NX15	LLZ015T4	5	45	3,68	4,61	5,72	7,03	8,56	2,18	2,34	2,48	2,61	2,76
	ICF-3CL11-NX17	LLZ018T4	6	45	4,36	5,47	6,79	8,34	10,15	2,53	2,72	2,88	3,04	3,21
Embraco Series	ICF-1CL11-E6.0	SE2006GS	2	45	1,16	1,43	1,76	2,15	2,62	1,24	1,31	1,38	1,45	1,53
	ICF-1CL11-E7.0	SE2008GS	2,5	45	1,48	1,82	2,24	2,75	3,35	1,57	1,66	1,75	1,84	1,94
	ICF-1CL11-E8.0	SE2010GS	3	45	1,74	2,14	2,63	3,23	3,94	1,83	1,93	2,03	2,14	2,25
	ICF-3CL11-EX12	SE2014GS	4	45	2,63	3,24	3,99	4,88	5,96	2,52	2,66	2,80	2,95	3,11
	ICF-3CL11-EX14	SE2017GS	5	45	3,12	3,84	4,73	5,79	7,07	2,90	3,05	3,22	3,39	3,57
	ICF-3CL11-EX17	SE2020GS	6	45	3,65	4,50	5,54	6,79	8,28	3,37	3,55	3,74	3,94	4,15

Tc: Condensing Temperature(°C)

Te: Evaporating Temperature (°C)

All duties are +/- 10%

Rating Condition: EN12900 RGT 20 °C

APPLICATION GUIDELINE



It should ensure that the refrigeration system which adopts this condensing unit, wherever possible to integrate pump down features. This is to avoid liquid compression which could damage the compressor.



Ensure that new compressors are not subjected to liquid abuse. Turn the crankcase heater on 12 hours before starting the compressor to avoid oil dilution and bearing malfunction.

Table 9: Operating Limits

Operating Limits	Recommendation
Maximum discharge gas temperature	Maximum 130°C
Low Pressure Side	Minimum: 0,5 bar; Maximum 19 bar
High Pressure Side	Maximum: 28 bars
Evaporator Outlet Superheat	Above 6k (to avoid liquid flood back)
Suction gas superheat at compressor inlet	Not more than 20K
Voltage supply	1phase: Min: 207V, Max: 253V 3phase: Min: 360V, Max: 440V
Phase asymmetry	+/- 2%
Frequency	50Hz +/- 1%
Outdoor ambient	Min: -20°C where head pressure control is recommended in low ambient conditions to avoid erratic TEV operation; Max: 43°C
Maximum pipe run	50m

Suction line shall be insulated to avoid:

- High superheat during high ambient condition can create high discharge temperature.
- Too low superheat during low ambient condition that can condense refrigerant inside suction line.

HEALTH AND SAFETY



CAUTION

Only qualified personnel, who are familiar with refrigeration systems and components including all controls, should perform the installation and start-up of the system. To avoid potential injury, use care when working around coil surfaces or sharp edges of metal cabinets. All piping and electrical wiring should be installed in accordance with all applicable standards and local by-laws.

General Information

Before Installation

- Ensure the units received are the correct models for the intended application.
- Ensure the refrigerant, voltage and maximum working pressure are all suitable for the proposed application.
- Check there is no damage to the units. Any damage should be reported to the supplier immediately.
- Check that the proposed equipment locations are suitable and provide adequate support for the weight of the units.

Offloading and Lifting

- Whenever a condensing unit is lifted, it should be from the base and, where possible, all packing and protection is kept in position.
- If lifting equipment is required, ensure that it is suitable, certificated, and that the operators are qualified to use it.
- When using a fork-lift or pallet truck to lift the unit, the two support points should be sufficiently apart to give stability when lifting and suitably placed to distribute the load on the forks.
- If slings are used, care should be taken to ensure that the slings do not crush the casework or coil.
- When lifting by crane, use spreader bars to prevent compressing the top of the equipment.
- Do not drop the unit. Should this inadvertently happen, it should be immediately unpacked and inspected for damage.
- Use the appropriate spreader bars/lifting sling with the holes and lugs provided.

During Installation and subsequent maintenance

- Installation and maintenance are to be performed only by qualified personnel who are familiar with local codes and regulations and experienced with this type of equipment.
- Safe working methods are identified, and operators should/must have suitable Personal Protective Equipment (PPE).
- Ensure the working area has adequate ventilation during brazing procedures.
- The units contain moving machinery and electrical power hazards, which may cause severe injury or death. Disconnect and shut off power before installation or service of the equipment.
- Refrigerant release into the atmosphere is illegal. Proper evacuation, recovery, handling, and leak testing procedures must be observed all the time.
- Units must be grounded to the screw terminal labelled



- No maintenance work should be attempted prior to disconnecting the electrical supply.

- The electrical covers and fan guards must remain fitted all the time.
- Use of the units outside of the design conditions and the application for which the units were intended may be unsafe and be detrimental to the units, regardless of short or long-term operation.
- The units are not designed to withstand loads or stress from other equipment or personnel. Such extraneous loads or stress may cause failure/leak/injury.
- The units are not designed to operate with any restrictions such as heavy snowfall around them. Additional measures (such as shielding of the units) shall be implemented as required.
- When the compressor operates under stabilized conditions, the oil level must be visible in the sight glass. Foam filling the oil sight glass indicates presence of large concentration of liquid to the compressor.
- No additional oil is required for installation with good oil returns, line runs up to 20m. Additional oil might be required if lines exceeded 20m, with minimum oil level must not lower than $\frac{1}{4}$ of sight glass. Top-up the oil while compressor is idle, via suction schrader connector with a suitable pump.
- Ensure correct rotation of scroll compressor. If there is no compression, shut off the incoming power supply and swap connection of any two of the three incoming phases at the condensing unit's motor rated circuit breaker.

INSTALLATION

Unit Location

- In order to achieve maximum cooling capacity, the installation location for the condensing unit should be carefully selected.
- Install the condensing unit in such a way so that hot air ejected by the condensing unit cannot be drawn in again (short circuit of hot discharge air). Allow sufficient space for maintenance around the unit.

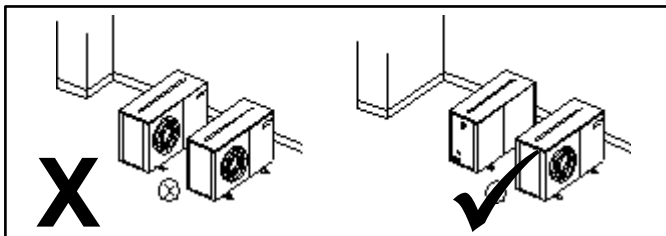

- Ensure that there is no obstruction to air flow into or out of the unit. Remove obstacles which block air intake or discharge.

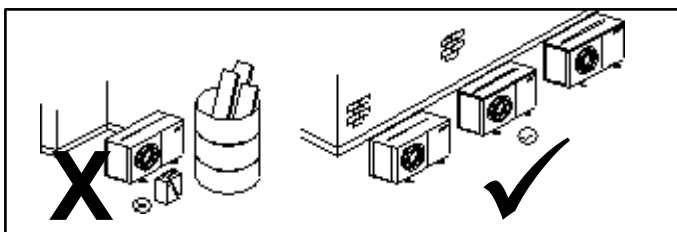

- The location must be well ventilated, so the unit can draw in and distribute plenty of air thus lowering the condensing temperature.
- To optimize the unit running conditions, the condenser coil must be cleaned at regular intervals.
- The unit must be level in all directions.
- It is recommended to install the unit on rubber grommets or vibration dampers



Special attention should be given if unit installed near to the sea as this can reduce unit lifespan due to corrosion of metal parts.

NOTICE

Installation Clearances

- The installation location should allow sufficient space for air flow and maintenance around the unit.

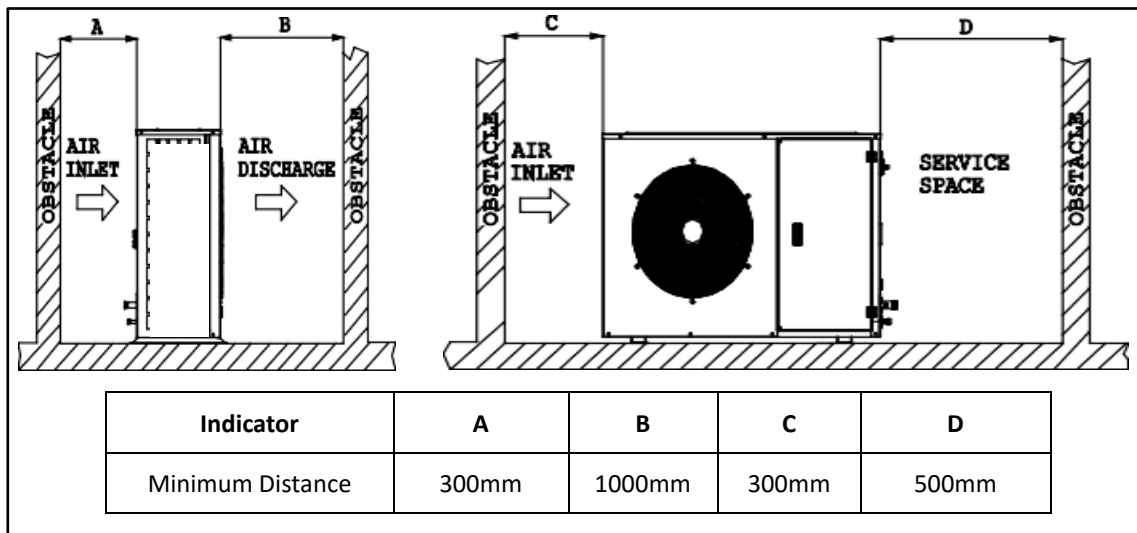

Field Piping



Pipe sizing should only be determined by qualified personnel. Correct line sizing will minimize the pressure drop and maintain sufficient gas velocity for proper oil return. All applicable standards must be observed in the installation of refrigerant piping.

NOTICE

To ensure satisfactory operation and performance, the following points should be noted:

- Pipework routes must be as simple and as short as possible
- Avoid low points of pipework where oil can accumulate.
- Use only clean, dehydrated refrigeration grade copper tube with long radius bends.
- Avoid flare type connections and take great care when brazing.
- Dissimilar metals such as copper and brass shall be joined using an appropriate flux with high silver content filler material. Apply flux sparingly to the clean tube only and in a manner to avoid leaving any excess inside of completed joints.
- Run braze without over filling to ensure there is no leakage into the tube.
- To prevent oxidation, blow oxygen free nitrogen through pipework when brazing.
- To prevent condensation on pipe surface, install insulation on all suction lines and on all pipes penetrating walls or passing through hot areas.
- Adequately support all pipe work at a maximum of 2-meter intervals.
- For the condensing unit located above the evaporator, the use of U-trap and double suction risers is often required. These suction risers must always be fitted with a U-Trap at the bottom and a P-Trap at the top never be higher than 4m unless a second U-Trap system is fitted.

- Liquid lines should be sized to ensure a full supply of liquid refrigerant to the expansion device.
- For the condensing unit located below the evaporator, attention should be paid to the sizing of liquid lines on vertical riser by limiting the maximum rise to 6m.
- For the outdoor unit located below indoor unit: Inverted P-trap is necessary when pump down is not used. To prevent refrigerant from draining into the compressor during off-cycle
- Suction pipework should slope gently back towards the unit to assist oil return to the compressor. A fall of approximately 2cm per meter of pipework is acceptable.
- Additional oil may be required if piping length exceeds 20m or multiple oil traps are fitted. Check the oil level closely during commissioning and add oil, as necessary. Add oil in small amounts. **Do not overfill the compressor!**
- In some circumstances, a suction accumulator (its optional component) may be required. It offers protection against liquid refrigerant flow back during operation and against off-cycle migration by adding internal free volume to the suction side of the system.
- Tests must be conducted to ensure the amount of off-cycle migration to the compressor does not exceed the compressor's charge limit.
- Wherever possible the system should be installed to utilize a pump down configuration.
- The maximum recommended pipe length is 50m.
- It is recommended to install Pressure Relief Valve on the liquid receiver if there is a risk of fire incidence. Increasing temperature will lead to pressure increase in receiver.
- No valves and detachable joints shall be in areas accessible to the public except when they comply with EN 16084.

Figure 1 / Figure 2: Piping Layouts

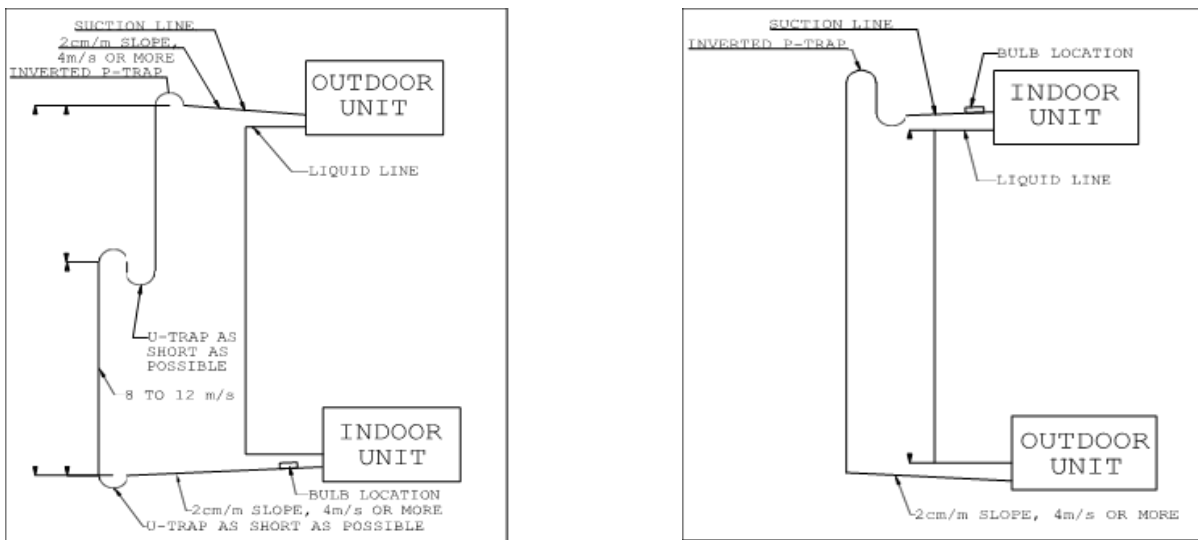

Pressure Testing



NOTICE

Never use oxygen, dry air or acetylene for pressure testing systems as these may form an inflammable mixture.

- The condensing units are pressure tested in the factory prior to dispatch. All units come with a holding charge of oxygen free nitrogen. Remove the holding charge and indication tag prior to pipework installation using the service valve or regulator with pressure gauges and hoses.
- Once the pipework installation is complete, it should be pressure tested for leak prior to evacuation.

- A pressure leak test should be carried out using oxygen free nitrogen (OFN). A calibrated nitrogen pressure regulator must always be used. Before starting any pressure testing, ensure that the area surrounding the system is safe, inform relevant personnel and fit warning signs indicating high pressure testing. Also, use the correct Personal Protection Equipment's.
- Always pressurize the system slowly, preferably in stages up to the maximum required pressure. Never exceed maximum test pressures shown in Table 6. Failure to obey the limit will cause premature failure on the pressure safety device.

Table 10: Test Pressure

High Side, bar
25

- Listen for any possible leaks and check all joints with bubble spray. If any leaks are discovered, release pressure slowly from both suction and liquid line of system until empty, repair leak and then repeat pressure testing procedure. Never attempt to repair a leak on a pressurized system.
- One testing has been completed satisfactorily, release the pressure from the system gradually and safety to external atmosphere.

Evacuation and Charging



Moisture prevents proper functioning of the compressor and the refrigeration system. Ensure that a good quality vacuum pump is used to pull a minimum vacuum of 250 microns measured at refrigeration system, and not at the vacuum pump gauge.

Once pressure testing has been completed, the system needs to be evacuated to remove any moisture from the piping. This can be done as follows:

- Ensure any nitrogen charge is safely released from the system.
- Connect a gauge manifold to the connections on the service valves on the condensing unit.
- Connect a vacuum pump and vacuum gauge to the system.
- Ensure all gauge manifold and service valves in open position.
- Evacuate the system until vacuum is below 250 microns.

Note: A triple evacuation procedure is recommended for all new systems or where moisture is suspected.

- Once the system is isolated and the vacuum pump is switched off, any rise in pressure indicates that either there may be a leak in the system or moisture is still present. In this case, recheck the system for leaks, repair as necessary, and then repeat the evacuation procedure.
- Once evacuation is completed satisfactorily, the vacuum pump and vacuum gauge can be removed. At this point, the refrigerant charge can be added to the system as required. Refrigerant blend must be charged in liquid form to avoid change of chemical properties.
- Ensure an adequate liquid charge (4-5bar) has been introduced to the high side of the system before starting the compressor.
- The remaining charge is slowly throttled into suction side until the installation has reached a level of stable nominal condition during operation. Charging liquid into the suction side of the system should ONLY be done with a metering device. Ensure a minimum operating pressure 0.5 bar is maintained when adding refrigerant to the suction side, otherwise overheating of the compressor may occur. Use calibrated weighing scales to record the amount of refrigerant added to the system.

- Stop the filling once obtain sufficient suction superheat and liquid subcooling, remove the cylinder from circuit.



Refrigerant charge by judging the liquid sight glass does not guarantee as 100% correct way.

NOTICE

Electrical



The main electrical supply to the condensing unit must be via a circuit breaker or fuse with appropriate motor capacity. Safety breakers are offered as an additional in our condenser units. When added, an additional isolator is not required unless site conditions or regulations dictate differently.

NOTICE

IBS Condensing units require power supply single or three phase which include Neutral and an Earth. These systems are not suitable for any other supply voltages (other than specified in **Table 9**).

- Mains supply cable type and size must be selected to suit the application and the electrical installation should conform to the current local standards.
- Cables to the condensing unit should, wherever possible, be routed through the cable glands supplied on the side of the units.
- Ensure that the power supply corresponds to the unit and that the power supply is stable.
- Connect power supply according to the present norm and legal requirement. Ensure that the unit is properly connected to the ground.
- 3 phase scroll compressors: live wires need correctly terminated at motor rated circuit breaker for the compressor to rotate in correct direction (compression).
- The unit is equipped with a motor circuit breaker with thermal overload and magnetic trip short circuit protection for the unit. It was preset from factory and never set value higher than set current on wiring diagram.

Reserve Rotation Protection and Voltage Unbalance



3 phase scroll compressors require proper phase sequence to secure right rotation and therefore compression.

NOTICE

IBS condenser units equipped with a 3-phase compressor include a phase protector as standard equipment. Thus, it is necessary to ensure correct incoming line voltage variance within +/- 2% during commissioning.

- Don't use a megohmmeter nor apply power to the compressor while the system under vacuum as this may cause internal damage to the compressor.
- Never start the compressor under vacuum (don't operate the compressor with the low-pressure cut-out bypassing), as this will cause the rotating part to overheat very quickly causing premature failure.
- There must be no more than 10 compressor's start per hour. A higher number reduces the service life of the compressor. There is no minimum off time for the compressors. Adequate minimum run time is required to ensure proper oil return.

COMMISSIONING

To gain access to the electrical box, turn the main switch on the electrical mains feeder or motor rated circuit breaker on the side/front of the unit to the OFF position and loose the screws on the left-hand side of the door. The electrical box is located behind the door. Remove the screws in the electrical box cover to access components.

Pre startup checks

Before starting the condensing unit, the following checks should be carried out as a minimum:

- Check electrical supply is correct and all connections are sound.
- All moving parts are free, and guards are fitted.
- Compressor oil level satisfactory.
- (If Any) Initial settings for safety switches and fan speed control
- Overload set correctly on motor rated circuit breaker.
- All valves are in correct operating position.
- Initial refrigerant charge.
- Crankcase heater energized for a minimum of 6 hours before compressor start-up.
- Gauge manifold connected to both low and high sides of system.

Running the Unit

- Turn the main switch on the electrical main feeder or motor rated circuit breaker on the side/front of the unit to the "ON" position. (It is optional equipment)
- Run the unit and check compressor and condenser fan operation.
- Check system pressures and temperatures, gas charge and running currents of motors to ensure correct operation.
- Check compressor suction superheat. This should be between 8K and 15K for normal operating conditions.
- (If Any) Final adjustment of safety switch settings and fan speed control.
- Allow the system to run for 3-4 hours. Check compressor oil level and top up with the correct oil type as required. Recheck the compressor oil level again after 24 hours operation.
- Carry out final leak test and ensure all panels/covers are fitted and screws tightened.
- Log all information along with the system model and serial numbers for future reference.
- Ensure that the customer/responsible person is provided with basic operating instructions and where electrical isolators are situated in case of emergency.

Scroll Compressor Operation

Scroll compressor motors are designed to run only in one direction. This is not an issue with single phase compressors as they will always run in the correct direction. The correct rotation of a three-phase compressor motor depends on the connection of the three incoming phases to the unit. Correct rotation can be determined by a drop in suction pressure and a rise in discharge pressure when the compressor is energized. Running the compressor for a short period of time in reverse direction will have no negative impact but prolonged running in reverse direction may cause premature failure. To reverse the rotation of a three-phase scroll compressor, shut off the incoming power supply to the unit, swap connection of any two of the three incoming phases at the unit motor rated circuit breaker, reapply power to the unit and following compressor restart, recheck operating pressures.

Pressure Switch Settings

Both the LP and HP switch settings must be adjusted to suit application before starting the unit. Ensure that the high-pressure setting doesn't exceed the value shown in **Table 11**.

High Pressure Safety

- The high-pressure safety switch is necessary to stop the compressor when the discharge pressure exceeds the compressor's high-side operating pressure.
- The high-pressure switch can be set to lower values depending on the application and ambient conditions.

Low pressure protection

- The low-pressure protection cut out switch protects the compressor against deep vacuum operation, a potential cause of failure due to internal arcing and operating outside the compressor limits.
- The low-pressure protection cut out should never be set lower than the min. LP cut out value in **Table 11**. For systems without pump-down integrated, the LP switch signal contact shall be used to energize a low-pressure safety alarm.
- If a thermostat is used for room temperature control, and a pump down feature is not integrated, a low-pressure control of the manual reset type should be wired in series with the thermostat to serve as a protection cut-off in the event of loss of refrigerant charge or other abnormal conditions which resulting in low suction pressures.
- When used for low temperature operational control, a low differential pressure should be applied to the low-pressure control for accurate control. For Accuracy, cooling pressure gauges should be used to set the cut-in and cut-out points, as the indicator on the front of the pressure switch isn't accurate enough for control purposes.
- Compressor operating pressures must be maintained within the limits specified in **Table 11**.

Table 11: Compressor Operating Pressures in bar

Series	Copeland	Danfoss	Embraco	Copeland	Danfoss	Embraco
Application	Medium T.			Low T.		
Compressor Family	ZB	MLZ	SE GS	ZF	LLZ	SE GS
Refrigerant	R404A R448A R449A R452A	R404A R448A R449A R452A	R404A R448A R449A R452A	R404A R448A R449A	R404A R448A R449A R452A	R404A R448A R449A R452A
Min LP Cut Out	2			0,3		
Max HP Cut Out	27,7			27,7		
LP Range	2,0-7,1			0,1-3,3		
HP Range	13,2-27,7			13,2-27,7		

Dual Pressure Switch (Optional Equipment)

The dual pressure switch fitted to condensing units is auto reset for low pressure side and high pressure are NOT factory preset for application.

Figure 3: Adjustment on Danfoss KP15

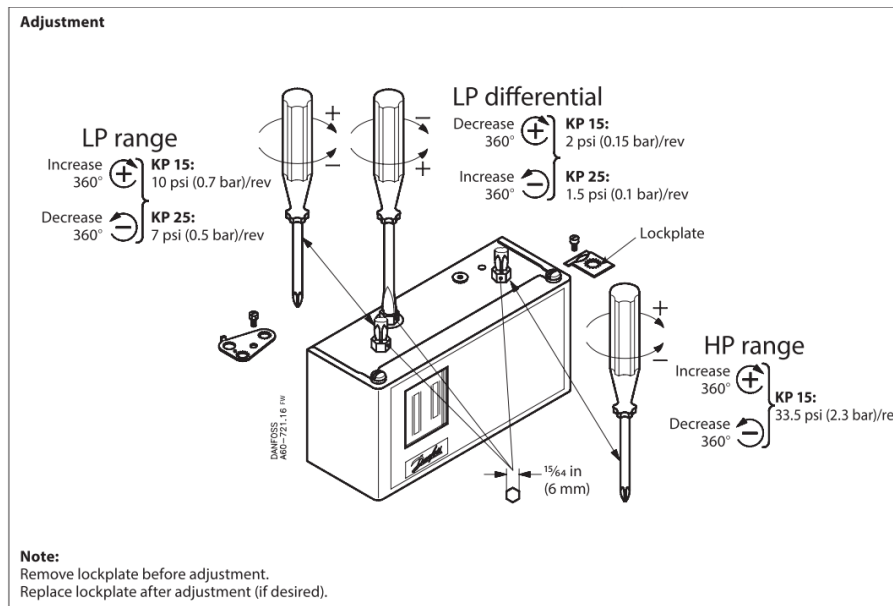

Table 12: Dual Pressure Switch Manufacturer Setting

Model	High (bar)		Low (bar)	
	Cut Out	Diff (Fixed)	Cut In	Diff (adj)
KP15	18	4	3	2

Fan Control Switch ACB-2UA 305W

The fan control switch is factory set as Table 13. Fan stopped when the pressure drop below fan cut out pressure.

Table 13: Fan Control Switch Factory Setting

Model	Fan control Switch (bar)	
	Cut in	Cut Out
ACB-2UA 305W	16	13

Fan Speed Controller XGE-4C (Optional Equipment)

The fan speed controller is factory set to 19barg (maximum speed) and cut off when drop below 13barg, for operation with R4*** series refrigerant to ensure compressor always operates within the unit operating envelope.

1 Turn	~1.5bar
Full voltage adjusting range	10~25barg
Full voltage set point (factory setting)	19barg full speed, mode: cut off at Pmin.
Effective proportional band	6 barg (fixed)



Crankcase Heaters

- Crankcase heater should remain energized during the compressor off cycles. The initial start in the field is a very critical period for any new compressor because all load-bearing surfaces are new and require a short break-in period to carry high loads under adverse conditions. Thus, the crankcase heater must be turned on a minimum of 6 hours before the first-time start, to prevent oil dilution and bearing stress on initial start-up.
- To energize the crankcase heater while keeping compressor OFF, isolate the compressor from circuit by removing jumper wire which in series with H/L pressure switch.

Signal Lamps (Optional Equipment)

- Optional signal lamps may be installed on the IBS for fault indication. The descriptions of these signal lamps are given below. These signals are for Hermetic Split Series.

- Phase Fault - The red LED lights up when there is a phase imbalance.
- High Pressure Fault - The red LED will light up when the high pressure exceeds the set value.
- Low Pressure Fault - The red LED lights up when the low-pressure drops below the set value.
- Thermic Fault - The red LED illuminates when the compressor displays a thermic fault.

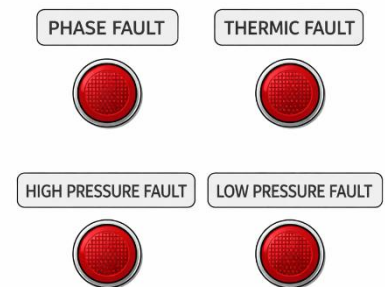

Safety Braker (Optional Equipment)

- It is an easily accessible, red-colored safety device that instantly cuts off the electricity to machinery or equipment in case of danger, thus protecting people and equipment.



Units with Microchannel Condenser

- Caution must be taken when charging a unit containing a microchannel condenser coil.
- The microchannel coils hold less refrigerant than traditional fin/tube coils, it is easier to be overcharged, especially if the system is commissioned during wintertime which ambient temperature is colder.
- Adding too much refrigerant can cause the high-pressure switch to malfunction in hot weather.
- Always check that the amount of condenser sub cooling isn't excessive which may indicate refrigerant overcharge.

System Operation

- Once the system is correctly charged with refrigerant and the operating condition is stable, check that the compressor suction superheat is between 8K-15K and that the compressor discharge temperature is between 50°C-90°C.
- A compressor suction superheat that is too low may indicate liquid refrigerant return to the compressor, whereas a suction superheat that is too high will not provide enough cooling effect for the compressor and will cause high discharge temperatures. In either case, it is likely that compressor damage/failure will occur.

CYCLE DIAGRAM AND EQUIPMENT

Mechanical Diagram with Standard Equipment's

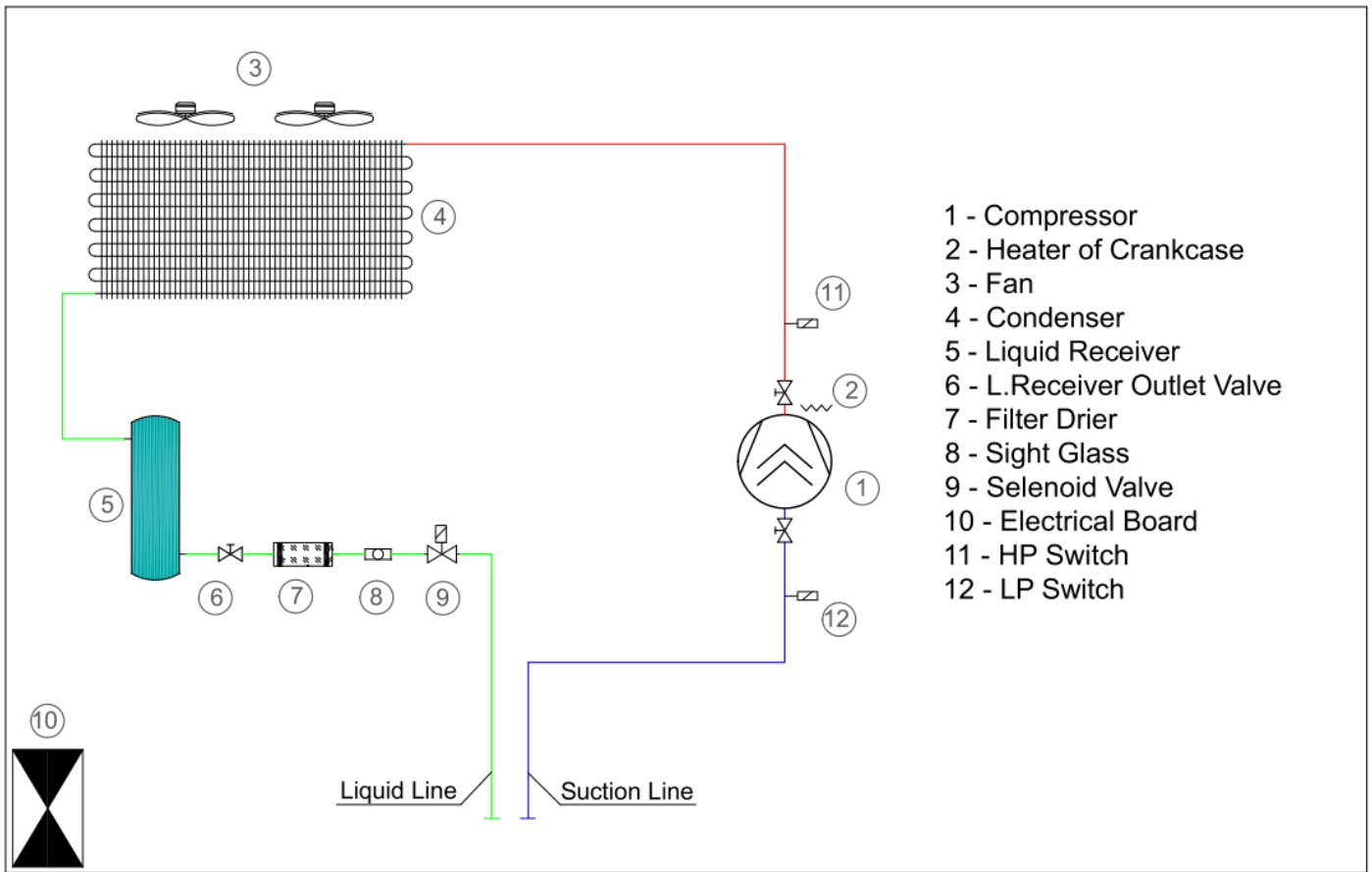

Mechanical Diagram with Optional Equipment's

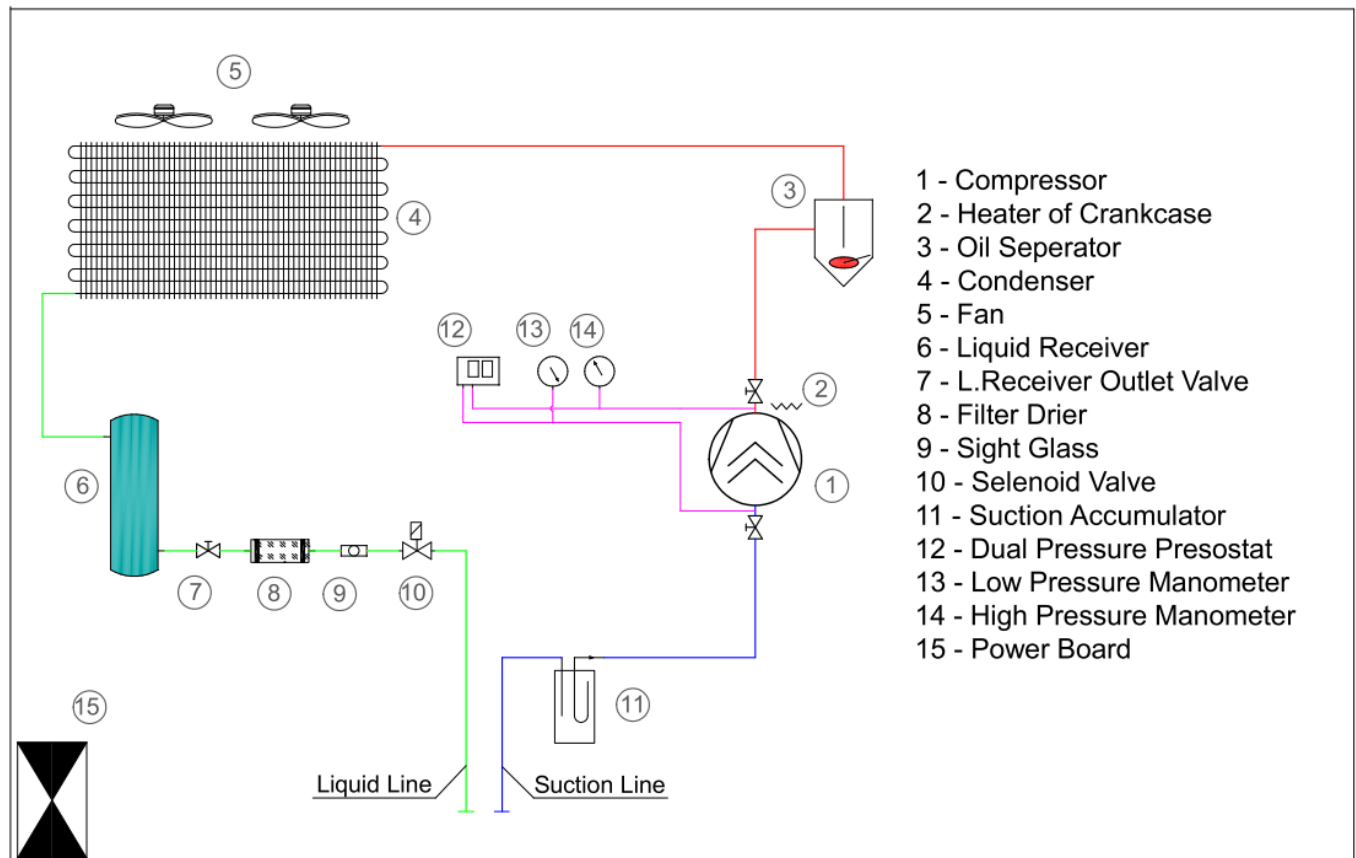

SERVICE & MAINTENANCE



Disconnect the main power supply before servicing and opening the unit.

IBS Condensing units are designed to give long life operation with minimum maintenance. However, they should be routinely checked, and the following service schedule is recommended under normal circumstances:

Removing the top, side and front panels will provide access to all components.

1. Compressor

Inspect at regular intervals.

- Check electrical connections.
- Check operation of crankcase heater.
- Check mountings for tightness and wear.
- Check for refrigerant leaks on all joints and fittings
- Ensure that no abnormal noise or vibration is detected during test run
- Check the compressor oil levels and top up if required. The oil level should be $\frac{1}{2}$ to $\frac{3}{4}$ way up the sight glass. (if sight glass is fitted)

2. Traditional Finned & Tube Coil Condenser and Fan Motor & Blade

Clean and inspect at regular interval.

- For optimal efficiency, clean the finned & tube condenser and the unit at least once a year.
- Ensure that the fan motor is clean and spins freely.
- Check that the condenser fan blade is clean and free from restriction and damage/imbalance.
- Check for abnormal noise, vibration, and fan imbalance
- Note: The fan motor is pre-lubricated, and factory sealed so no maintenance is necessary.

3. Microchannel Condenser Coil

Clean and inspect at regular intervals.

- Remove surface dirt, leaves etc. with a vacuum cleaner (preferably with a brush or other soft attachment rather than a metal tube), compressed air blown from the inside out, and/or a soft bristle (not wire!) brush. Don't impact or scrape the coil with the vacuum tube, air nozzle, etc.
- Microchannel heat exchangers tend to retain more water than traditional finned and tube coils due to their fin geometry. Depending on the specific design and installation of your coil, it may be beneficial to blow or vacuum away the rinse water from the unit to speed up the drying process and prevent water accumulation.
- **DON'T** use any chemicals to wash microchannel heat exchangers (includes those marketed as coil cleaners). They can cause corrosion. Simple rinse. Clean the Microchannel gently, preferably from the inside out and from top to bottom, by running water through each fin passage. Microchannel fins are stronger than conventional tubular and finned coil fins, but should still be handled carefully. Don't strike the coil hard with the hose. We recommend covering the end of the hose with your thumb

instead of a nozzle tip, as this makes the spraying gentler and reduces the likelihood of impact damage.

4. Controls

- Check settings and operation of pressure switches.
- Check overload setting.
- (If any) Check fan speed control settings and operation.

5. Power Supply

Inspect at regular intervals.

- Check the running current and voltage for the condensing unit.
- Check the electrical wiring and tighten the wires onto the terminal blocks if necessary.

6. Refrigerant Charge

- Check the refrigerant charge, ensuring the system is functioning correctly, pressures are as expected, and the fluid level indicator shows a full refrigerant level.
- Perform a complete leak test.

7. Compressor Replacement

- The rotalock connections used on some compressor models are factory sealed with sealant. If the rotalock connections need to be disassembled (e.g., compressor change), then they should be thoroughly cleaned and sealant reapplied before reassembly. In case of difficulty undoing the connections due to the sealant, apply heat to the rotalock using a heat gun for several minutes and then loosen using hand tools while hot.

8. Unit decommissioning and disposal

- At the end of the unit's useful life, the appliance must be decommissioned by suitably operating/service personnel. Refrigerant and compressor oil are classified as hazardous waste and therefore must be properly recovered and disposed of, including completing waste transfer documentation. The appliance components must be properly disposed of or recycled.

9. Warranty

- The warranty on products manufactured by IBS is contingent upon correct application, placement, and installation procedures, as well as registered maintenance/service performed in accordance with our recommendations. Failure to do so may violate our warranty.

F-GAS REQUIREMENT

The models of equipment discussed in this Operational Manual rely on fluorinated greenhouse gases to perform their functioning.

All condensing unit models come from the factory pressurized with Oxygen Free Nitrogen (OFN) only.

In the EU 517/2014 F-Gas Regulation, the requirement for leak testing in a system is based on the CO₂ equivalent charge amount in tons. This means that systems using refrigerants with a higher GWP must be leak tested more frequently than systems using refrigerants with a lower GWP at the same charge weight.

The three new threshold values for leak testing requirements based on Global Warming Potential (GWP) and T CO₂Eq (Tons of CO₂ Equivalent) of refrigerants specified for use are as follows:

Refrigerant	GWP	Refrigerant Charge- kg		
		5T CO ₂ Eq	50T CO ₂ Eq	500T CO ₂ Eq
R32	675	7,41	74,1	741
R134A	1430	3,49	34,9	349
R404A	3922	1,28	12,8	128
R407A	2107	2,4	24	240
R407C	1774	2,82	28,2	282
R407F	1387	3,6	36	360
R410A	2088	2,39	23,9	239
R422D	2729	1,83	18,3	183
R448A	1387	3,6	36	360
R449A	1397	3,6	35,8	358
R1234ze	7	714,3	7143	71430

Previous Limits For Testing	3kg	30kg	300kg
------------------------------------	------------	-------------	--------------

From January 1, 2017, the requirement for leak detection and system logging has changed from 3 kg of HFC to 5 T CO₂Eq.

$$TCO_2 Eq = \frac{\text{Refrigerant Charge (kgs)} \times \text{Refrigerant GWP}}{1000}$$

A refrigerant charge label is supplied with each unit (inside the electrical box). The total refrigerant charge for the system and the TCO₂ Eq to be calculated using the above formula and the values must be entered on the label with indelible ink. The label must be adhered to the proximity of the product charging port. The label supplied will represent the refrigerants approved for use with that unit.

WIRING DIAGRAMS

With Standard Equipment's

Figure 4: Monophase Split Hermetic Condensing Units with 1 Fan

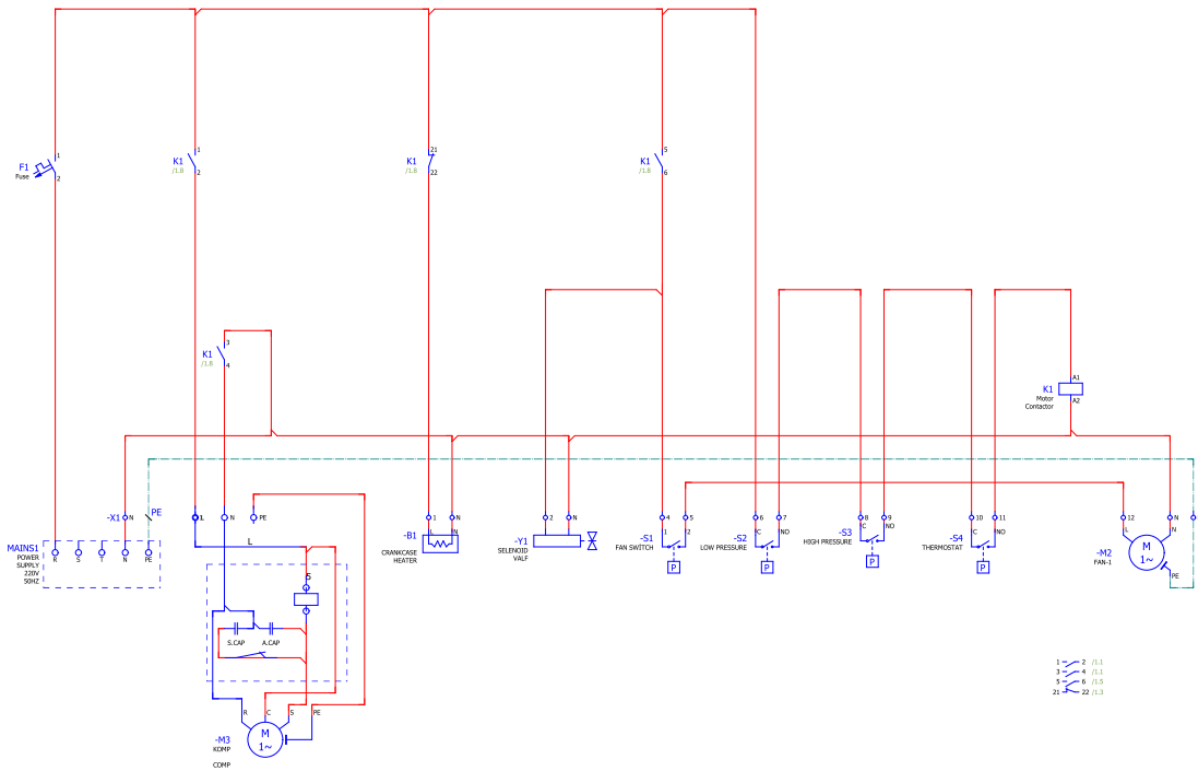

Figure 5: Three phase Split Hermetic Condensing Units with 1 Fan

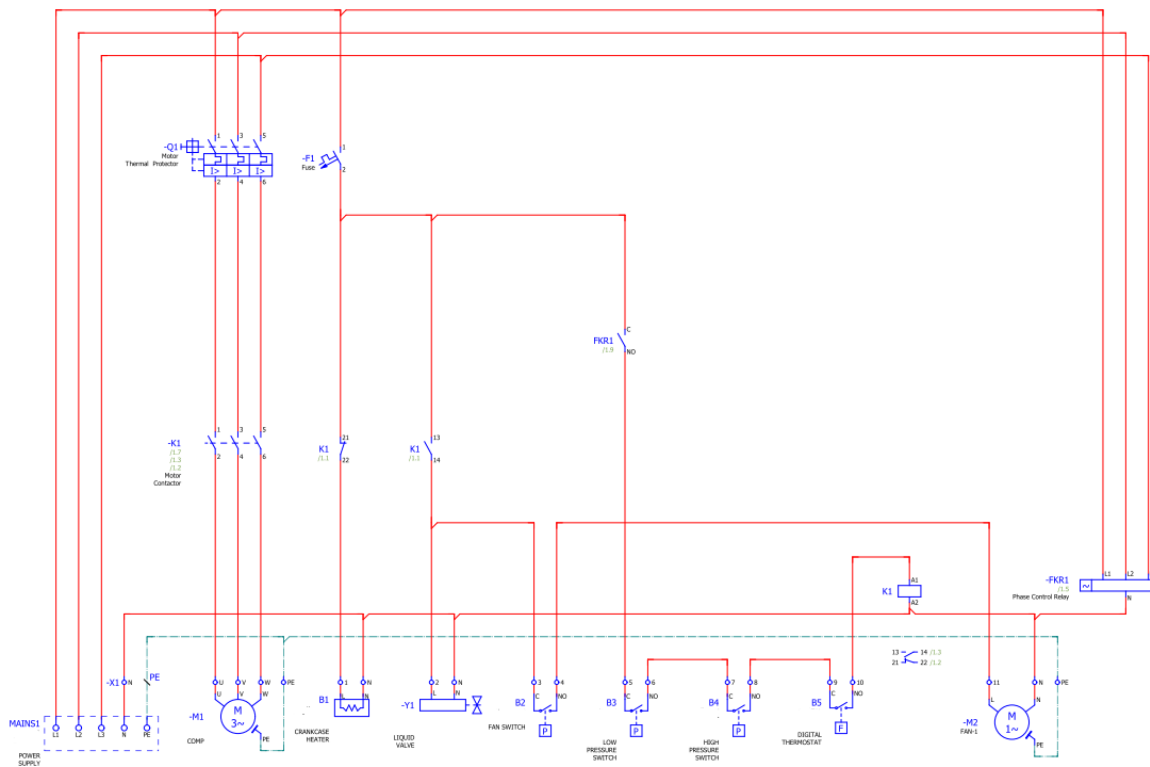

Figure 6: Three phase Split Hermetics Condensing Units with 2 Fans

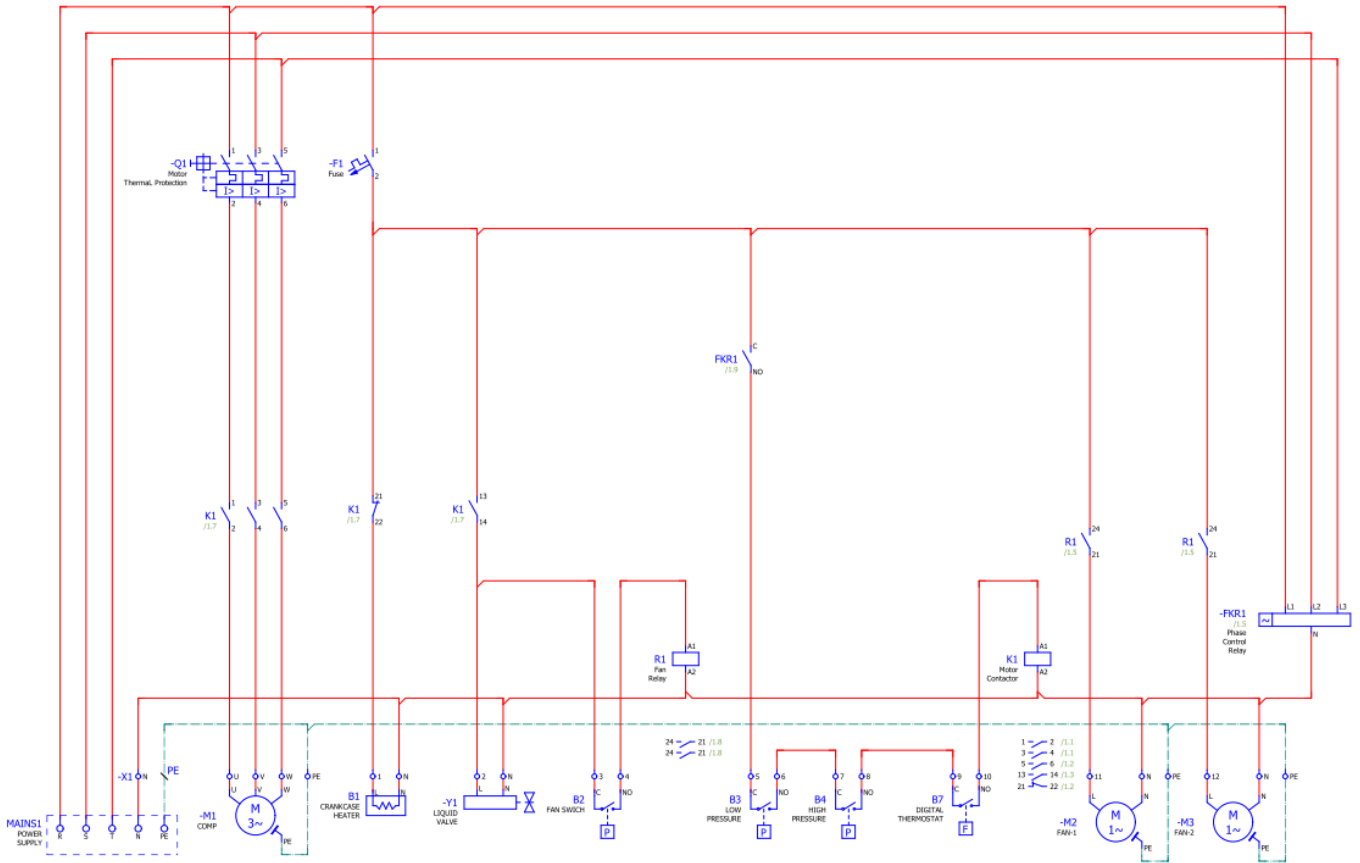
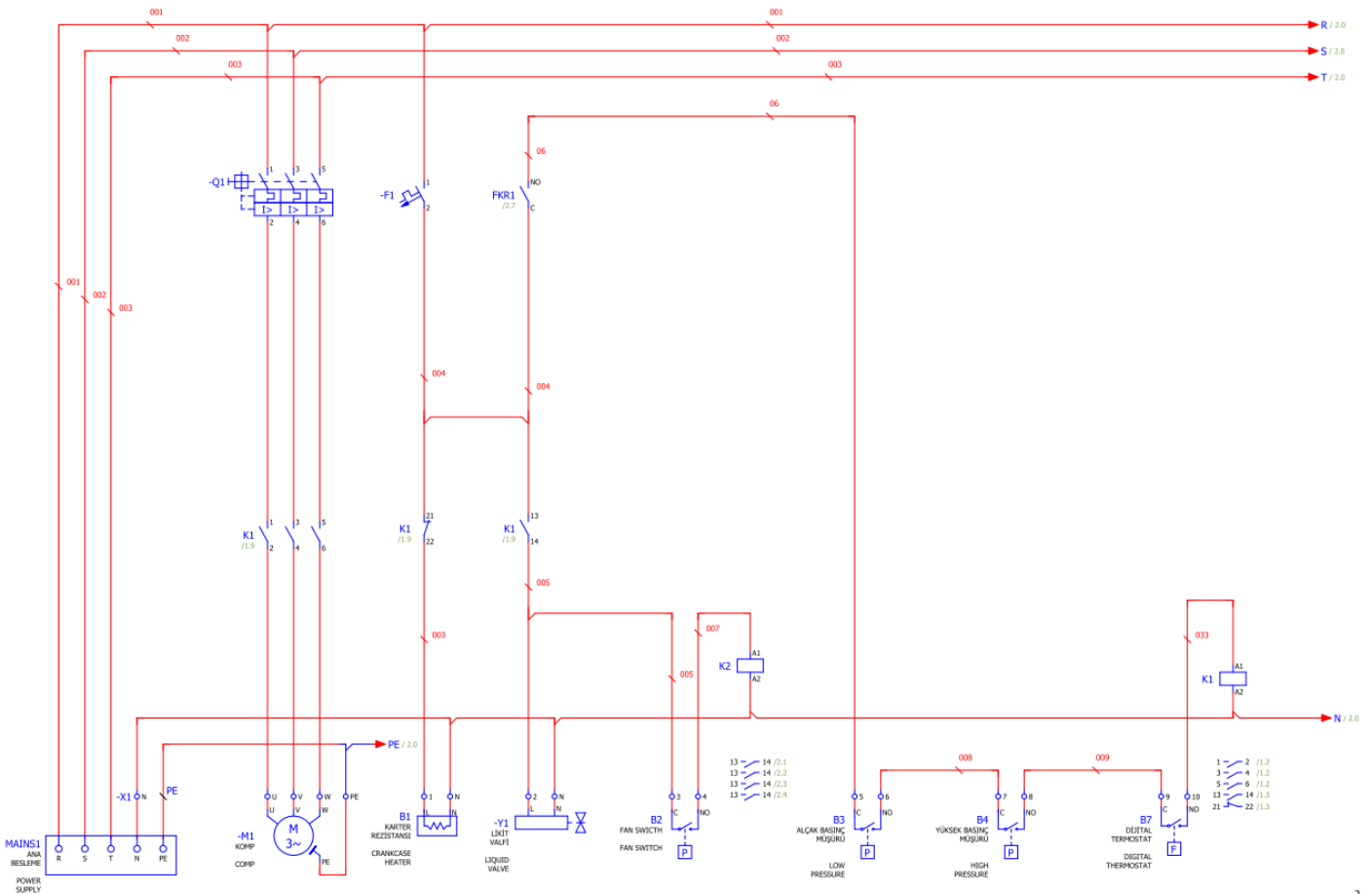
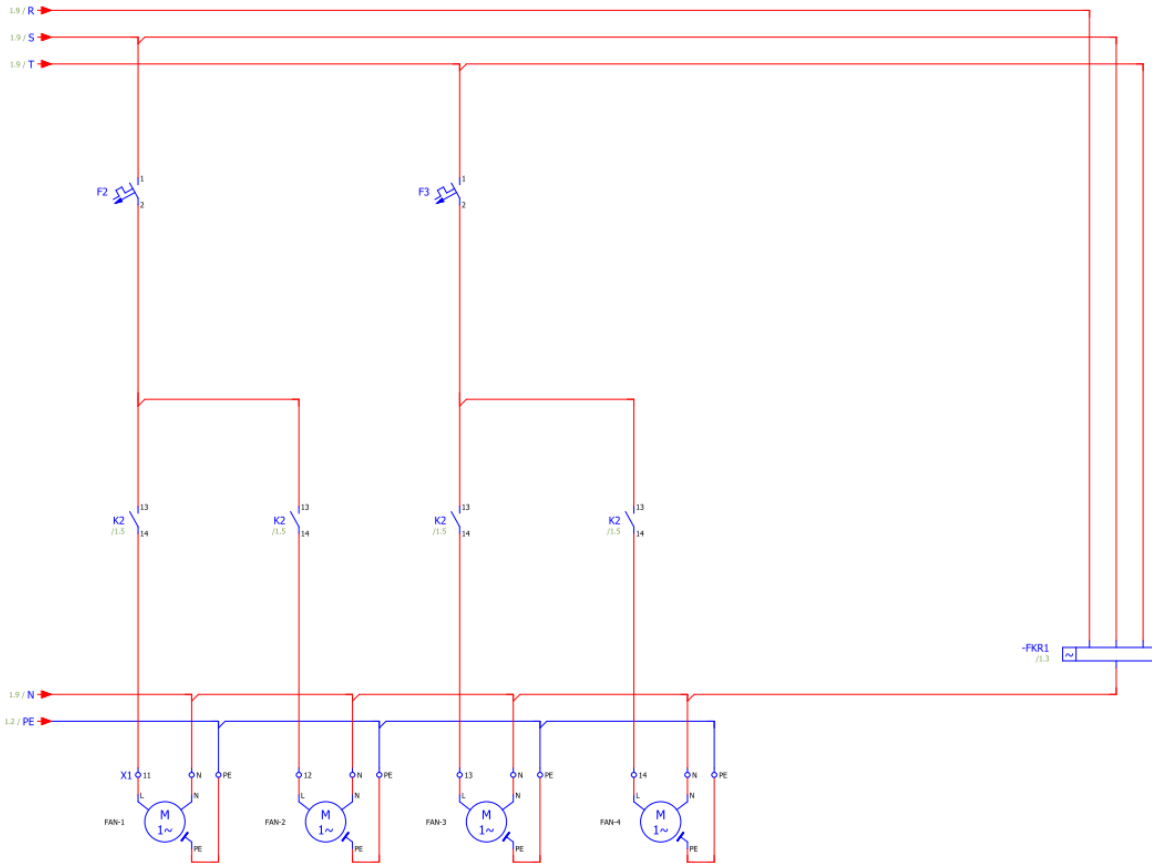

Figure 7: Three phase Split Hermetics Condensing Units with 4 Fans





With Full Optional Equipment's

Figure 8: Monophase Split Hermetic Condensing Units with 1 Fan

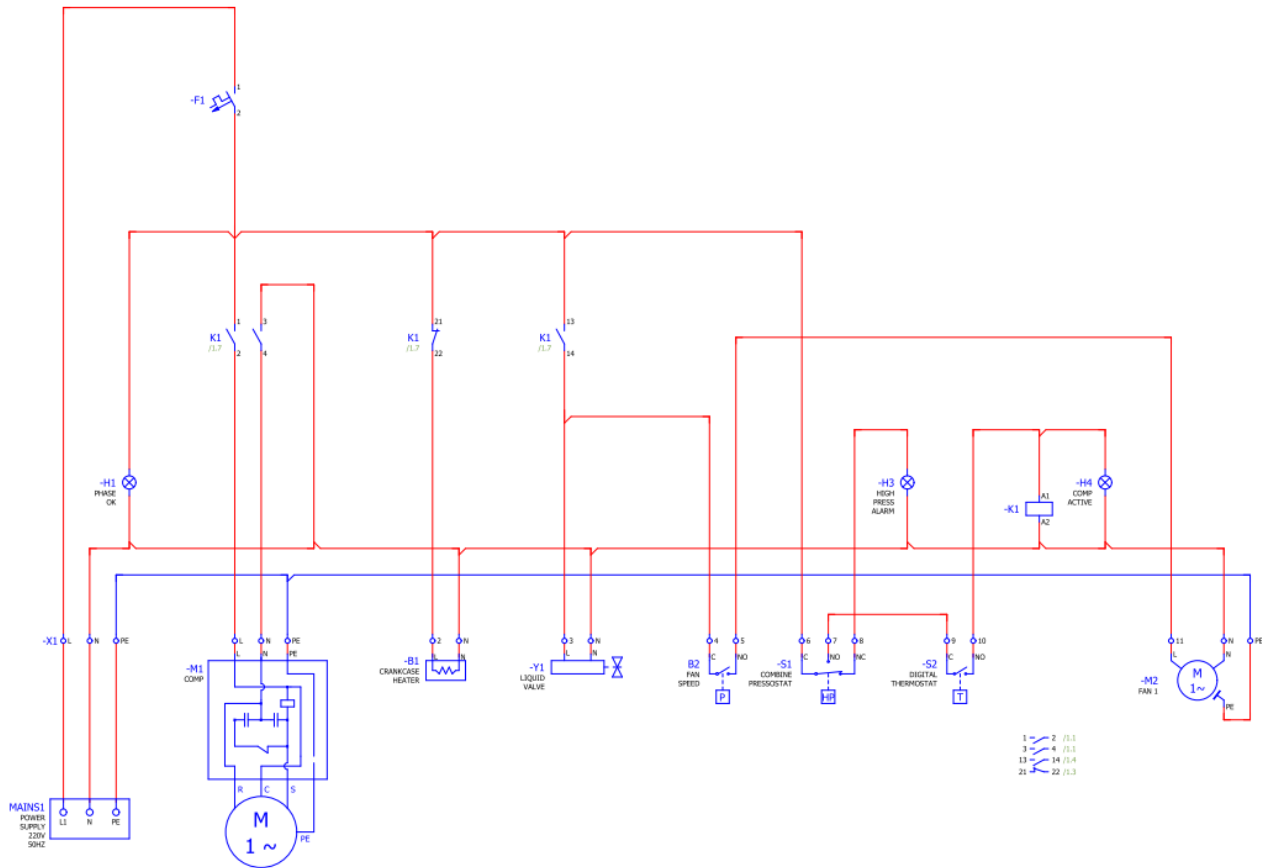

Figure 9: Three phase Split Hermetic Condensing Units with 1 Fan

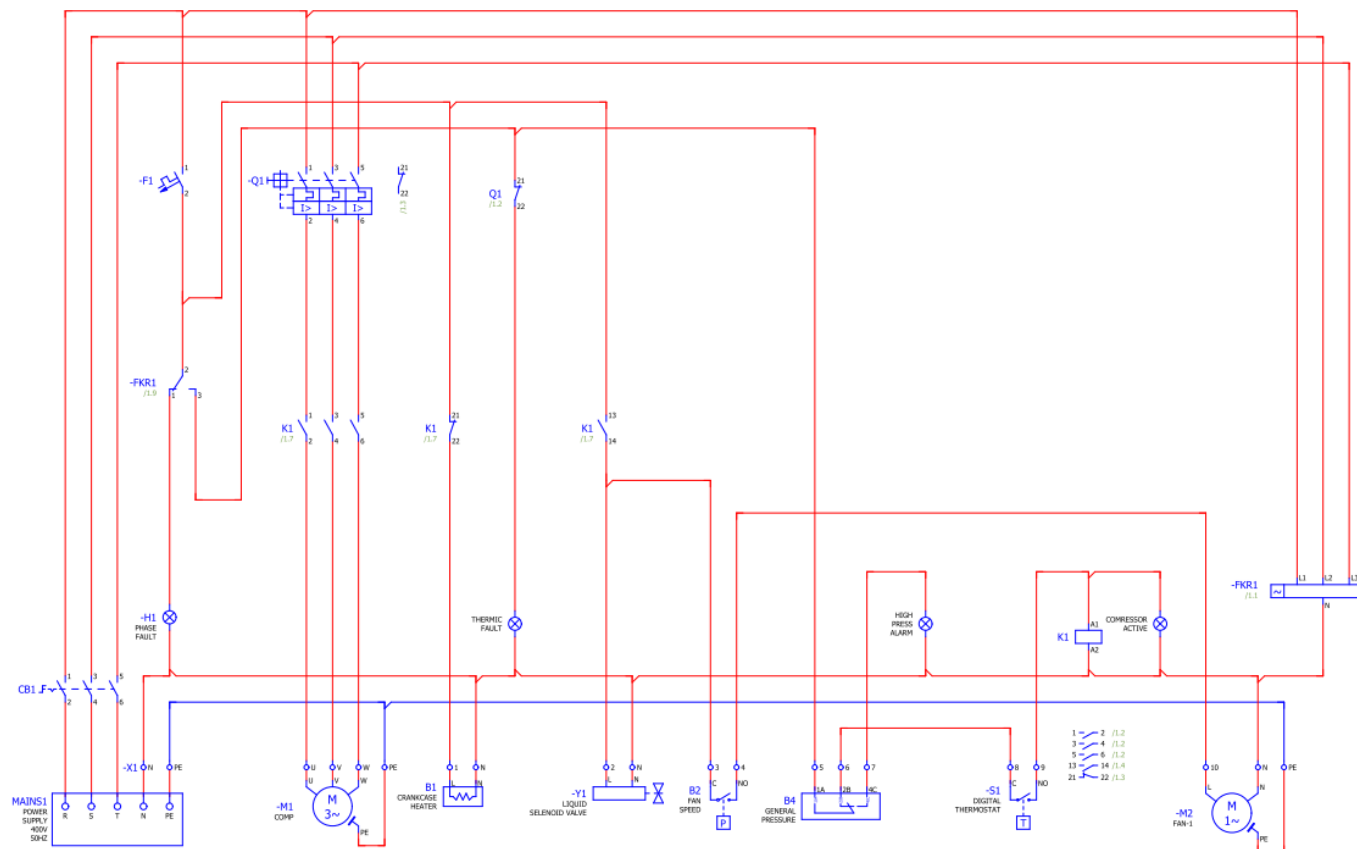

Figure 10: Three phase Split Hermetic Condensing Units with 2 Fans

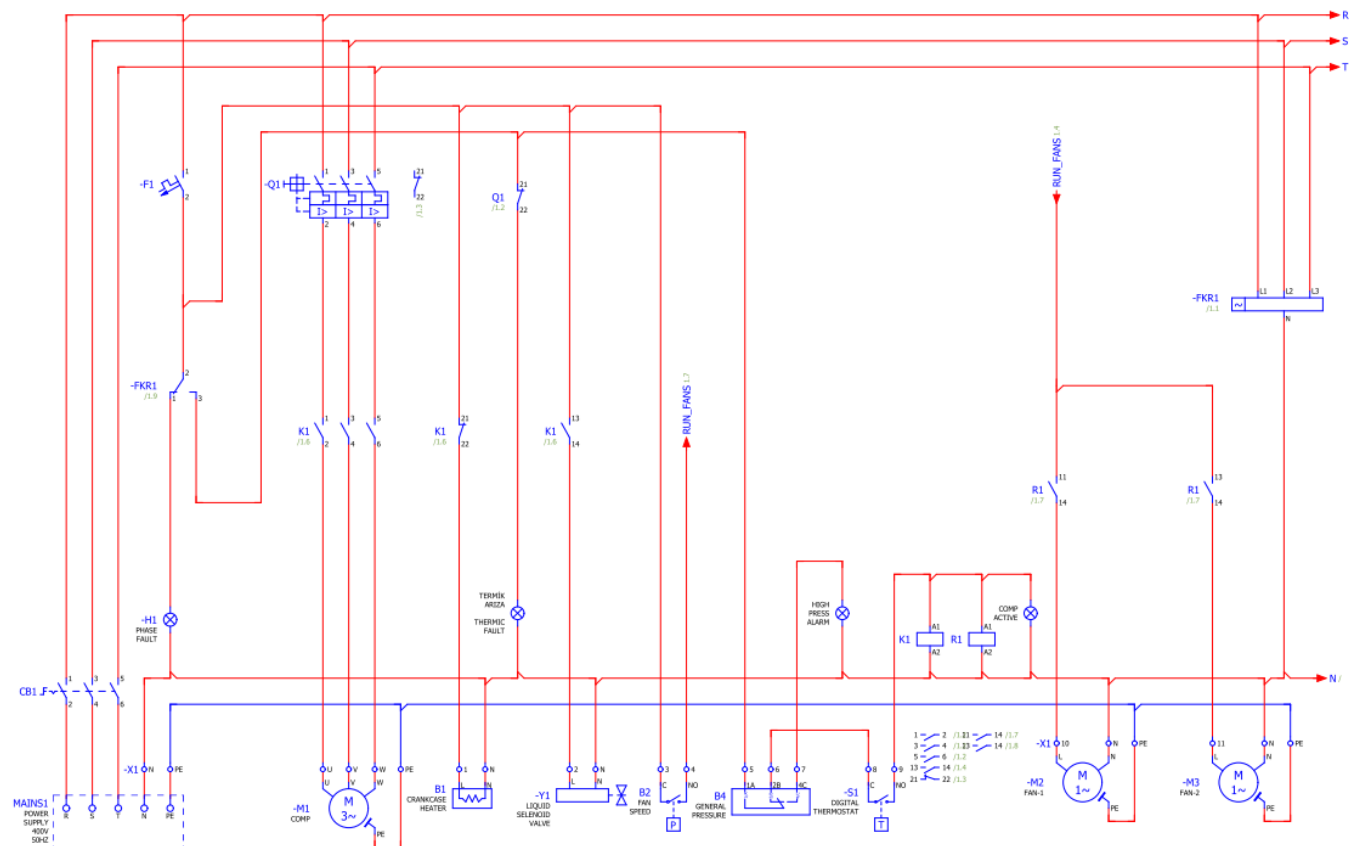
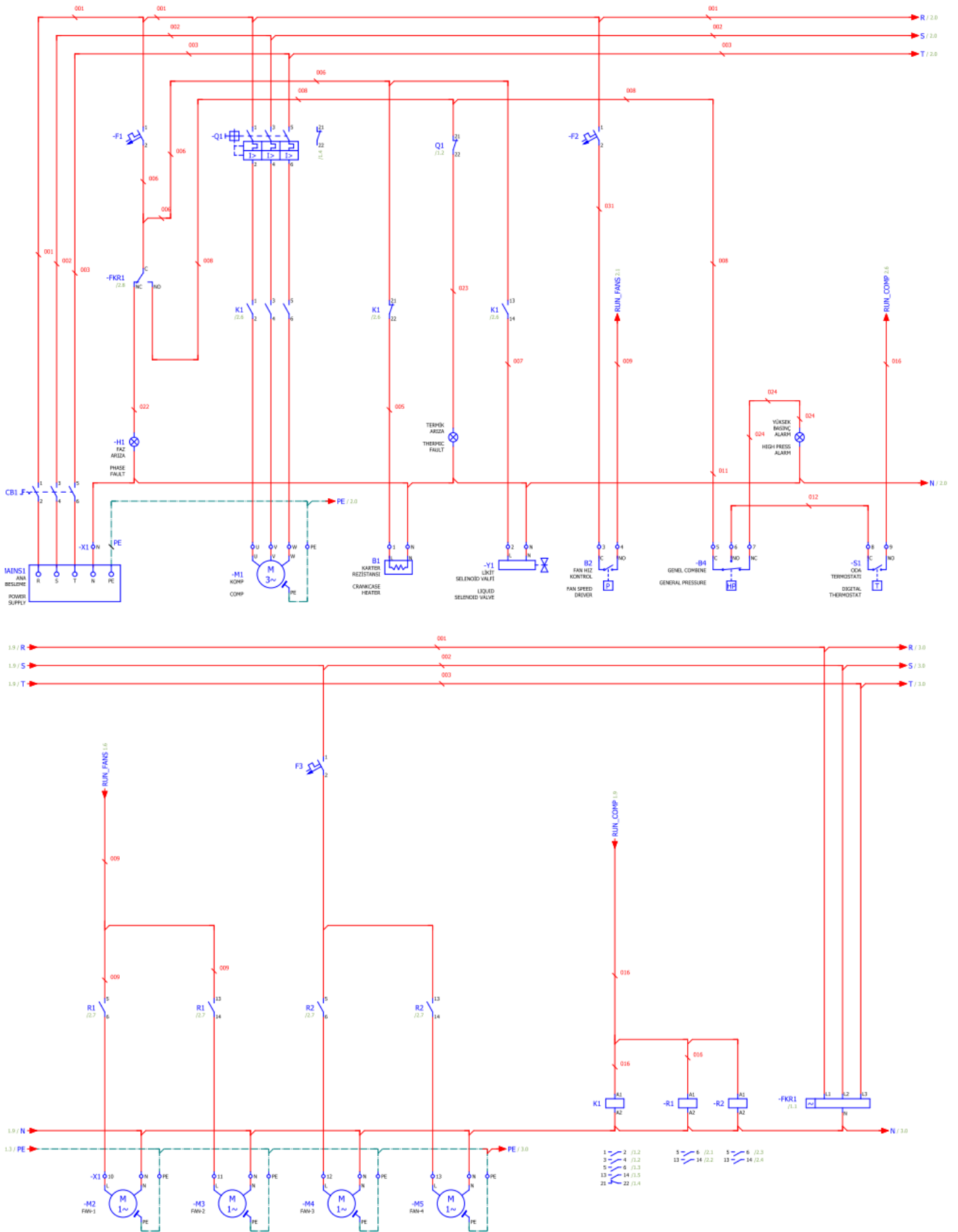
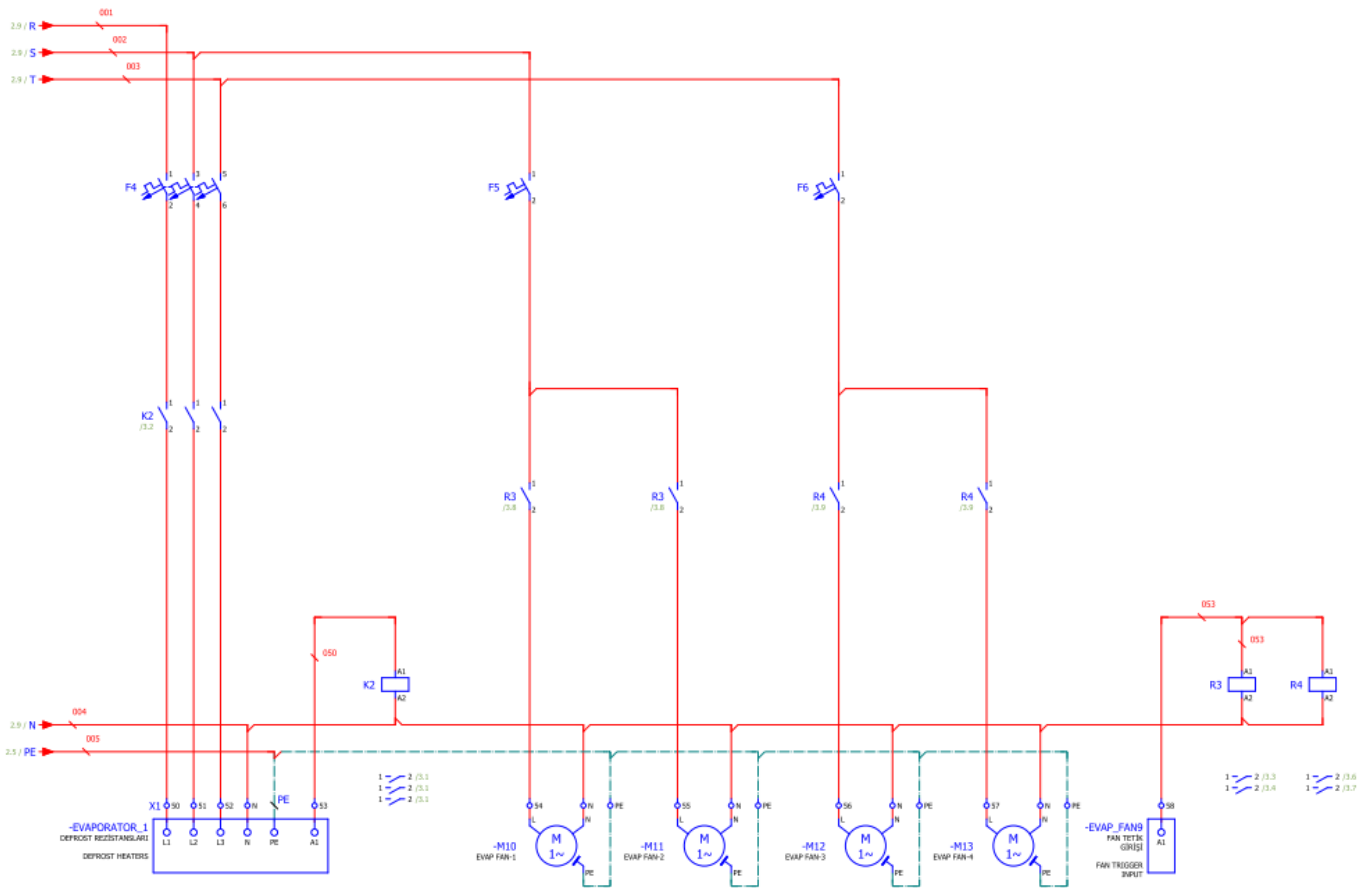

Figure 11: Three phase Split Hermetic Condensing Units with 4 Fans





CABIN

Cabin Lists

The cabinet types used for IBS Condensing Units with the optional oil separator and suction accumulator are listed below.

Cabinet drawings and their dimensions are provided after the tables

Table 14: Standard Series (Copeland)

			1400 RPM				
Brand	Model	IBS Model	Condanser Surf. Area	Cabin	Oil Seperator	Suction Accumulator	Oil Sep.+ Suction Accu.
Copeland	ZB15	ICF-1CM11-C5.9Z4	15	F1 00	F1 xx	F1 30	F1 30
Copeland	ZB19	ICF-1CM11-C6.8Z4	20	F1 00	F1 xx	F1 30	F1 30
Copeland	ZB21	ICF-3CM11-C8.6Z4	28	F3 20	F3 20	F3 20	F3 24
Copeland	ZB26	ICF-3CM11-CX10Z4	28	F3 20	F3 20	F3 20	F3 24
Copeland	ZB29	ICF-3CM11-CX12Z4	28	F3 20	F3 20	F3 20	F3 24
Copeland	ZB38	ICF-4CM12-CX14Z4	44	F4 20	F4 20	F4 22	F4 33
Copeland	ZB45	ICF-4CM12-CX17Z4	44	F4 20	F4 20	F4 22	F4 33
Copeland	ZB48	ICF-4CM12-CX19Z4	58	F4 20	F4 20	F4 22	F4 33
Copeland	ZB58	ICF-5CM12-CX21Z4	66	F5 22	F5 34	F5 34	F5 34
Copeland	ZB76	ICF-5CM12-CX29Z4	83	F5 22	F5 34	F5 34	F5 34
Copeland	ZB95	ICF-7CM14-CX36Z4	94	F7 15	F7 65	F7 65	F7 65
Copeland	ZF09	ICF-1CL11-C8.0Z4	20	F1 00	F1 xx	F1 xx	F1 30
Copeland	ZF11	ICF-3CL11-C9.9Z4	28	F3 20	F3 20	F3 24	F3 24
Copeland	ZF13	ICF-3CL11-CX12Z4	28	F3 20	F3 20	F3 24	F3 24
Copeland	ZF15	ICF-3CL11-CX15Z4	28	F3 20	F3 20	F3 24	F3 24
Copeland	ZF18	ICF-3CL11-CX17Z4	37	F3 20	F3 20	F3 24	F3 24
Copeland	ZF25	ICF-4CL12-CX21Z4	44	F4 22	F4 33	F4 33	F4 54
Copeland	ZF34	ICF-4CL12-CX29Z4	44	F4 22	F4 33	F4 33	F4 54
Copeland	ZF41	ICF-5CL12-CX35Z4	66	F5 22	F5 34	F5 34	F5 54
Copeland	ZF49	ICF-5CL12-CX43Z4	83	F5 22	F5 34	F5 34	F5 54

Table 15: Silence Series (Copeland)

			900 Rpm				
Brand	Model	IBS Model	Condanser Surf. Area	Cabin	Oil Seperator	Suction Accumulator	Oil Sep.+ Suction Accu.
Copeland	ZB15	ICF-3CM11-C5.9Z6	28	F3 20	F3 20	F3 20	F3 24
Copeland	ZB19	ICF-3CM11-C6.8Z6	28	F3 20	F3 20	F3 20	F3 24
Copeland	ZB21	ICF-3CM11-C8.6Z6	28	F3 20	F3 20	F3 20	F3 24
Copeland	ZB26	ICF-3CM11-CX10Z6	37	F3 20	F3 20	F3 20	F3 24
Copeland	ZB29	ICF-3CM11-CX12Z6	37	F3 20	F3 20	F3 20	F3 24
Copeland	ZB38	ICF-4CM12-CX14Z6	44	F4 20	F4 20	F4 22	F4 33
Copeland	ZB45	ICF-4CM12-CX17Z6	58	F4 20	F4 20	F4 22	F4 33
Copeland	ZB48	ICF-5CM12-CX19Z6	66	F5 22	F5 22	F5 22	F5 34
Copeland	ZB58	ICF-5CM12-CX21Z6	83	F5 22	F5 34	F5 34	F5 34
Copeland	ZB76	ICF-6CM14-CX29Z6	87	F6 06	F6 65	F6 65	F6 65
Copeland	ZB95	ICF-7CM14-CX36Z6	125	F7 15	F7 65	F7 65	F7 65
Copeland	ZF09	ICF-3CL11-C8.0Z6	28	F3 20	F3 20	F3 24	F3 24
Copeland	ZF11	ICF-3CL11-C9.9Z6	28	F3 20	F3 20	F3 24	F3 24
Copeland	ZF13	ICF-3CL11-CX12Z6	28	F3 20	F3 20	F3 24	F3 24
Copeland	ZF15	ICF-3CL11-CX15Z6	37	F3 20	F3 20	F3 24	F3 24
Copeland	ZF18	ICF-4CL12-CX17Z6	44	F4 20	F4 20	F4 20	F4 22
Copeland	ZF25	ICF-4CL12-CX21Z6	44	F4 22	F4 33	F4 33	F4 54
Copeland	ZF34	ICF-5CL12-CX29Z6	66	F5 22	F5 34	F5 34	F5 54
Copeland	ZF41	ICF-6CL14-CX35Z6	87	F6 06	F6 65	F6 65	F6 65
Copeland	ZF49	ICF-6CL14-CX43Z6	87	F6 06	F6 65	F6 65	F6 65

Table 16: Standard Series (Danfoss)

			1400 RPM				
Brand	Model	IBS Model	Condanser Surf. Area	Cabin	Oil Seperator	Suction Accumulator	Oil Sep.+ Suction Accu.
Danfoss	MLZ15	ICF-1CM11-N5.9Z4	15	F1 00	F1 xx	F1 30	F1 30
Danfoss	MLZ19	ICF-1CM11-N7.6Z4	20	F1 00	F1 xx	F1 30	F1 30
Danfoss	MLZ21	ICF-3CM11-N8.0Z4	28	F3 20	F3 20	F3 20	F3 24
Danfoss	MLZ26	ICF-3CM11-N9.9Z4	28	F3 20	F3 20	F3 20	F3 24
Danfoss	MLZ29	ICF-3CM11-NX12Z4	28	F3 20	F3 20	F3 20	F3 24
Danfoss	MLZ38	ICF-4CM12-NX14Z4	44	F4 20	F4 20	F4 22	F4 33
Danfoss	MLZ45	ICF-4CM12-NX17Z4	44	F4 20	F4 20	F4 22	F4 33
Danfoss	MLZ48	ICF-4CM12-NX19Z4	58	F4 20	F4 20	F4 22	F4 33
Danfoss	MLZ58	ICF-5CM12-NX22Z4	66	F5 22	F5 34	F5 34	F5 34
Danfoss	MLZ76	ICF-5CM12-NX28Z4	83	F5 22	F5 34	F5 34	F5 34
Danfoss	LLZ 013	ICF-3CL11-NX12Z4	28	F3 20	F3 20	F3 24	F3 24
Danfoss	LLZ 015	ICF-3CL11-NX15Z4	28	F3 20	F3 20	F3 24	F3 24
Danfoss	LLZ 018	ICF-3CL11-NX17Z4	37	F3 20	F3 20	F3 24	F3 24

Table 17: Silence Series (Danfoss)

			900 Rpm				
Brand	Model	IBS Model	Condanser Surf. Area	Cabin	Oil Seperator	Suction Accumulator	Oil Sep.+ Suction Accu.
Danfoss	MLZ15	ICF-3CM11-N5.9Z6	28	F3 20	F3 20	F3 20	F3 24
Danfoss	MLZ19	ICF-3CM11-N7.6Z6	28	F3 20	F3 20	F3 20	F3 24
Danfoss	MLZ21	ICF-3CM11-N8.0Z6	28	F3 20	F3 20	F3 20	F3 24
Danfoss	MLZ26	ICF-3CM11-N9.9Z6	37	F3 20	F3 20	F3 20	F3 24
Danfoss	MLZ29	ICF-3CM11-NX12Z6	37	F3 20	F3 20	F3 20	F3 24
Danfoss	MLZ38	ICF-4CM12-NX14Z6	44	F4 20	F4 20	F4 22	F4 33
Danfoss	MLZ45	ICF-4CM12-NX17Z6	58	F4 20	F4 20	F4 22	F4 33
Danfoss	MLZ48	ICF-5CM12-NX19Z6	66	F5 22	F5 22	F5 22	F5 34
Danfoss	MLZ58	ICF-5CM12-NX22Z4	83	F5 22	F5 34	F5 34	F5 34
Danfoss	MLZ76	ICF-6CM14-NX28Z6	87	F6 06	F6 65	F6 65	F6 65
Danfoss	LLZ 013	ICF-3CL11-NX12Z6	28	F3 20	F3 20	F3 24	F3 24
Danfoss	LLZ 015	ICF-3CL11-NX15Z6	37	F3 20	F3 20	F3 24	F3 24
Danfoss	LLZ 018	ICF-4CL12-NX17Z6	44	F4 20	F4 20	F4 20	F4 22

Table 18: Standard Series (Embraco)

			1400 RPM				
Brand	Model	IBS Model	Condanser Surf. Area	Cabin	Oil Seperator	Suction Accumulator	Oil Sep.+ Suction Accu.
Embraco	SE6015GS	ICF-1CM11-E6.0Z4	20	F1 00	F1 30	F1 30	F1 30
Embraco	SE6018GS	ICF-3CM11-E7.0Z4	28	F3 20	F3 20	F3 20	F3 24
Embraco	SE6021GS	ICF-3CM11-E8.0Z4	28	F3 20	F3 20	F3 20	F3 24
Embraco	SE6030GS	ICF-3CM11-EX12Z4	37	F3 20	F3 20	F3 20	F3 24
Embraco	SE6036GS	ICF-4CM12-EX14Z4	44	F4 20	F4 20	F4 20	F4 33
Embraco	SE6043GS	ICF-4CM12-EX17Z4	44	F4 20	F4 20	F4 20	F4 33
Embraco	SE6053GS	ICF-4CM12-EX20Z4	57	F4 20	F4 20	F4 20	F4 33
Embraco	SE6056GS	ICF-5CM12-EX21Z4	66	F5 22	F5 34	F5 34	F5 34
Embraco	SE6067GS	ICF-5CM12-EX25Z4	83	F5 22	F5 34	F5 34	F5 34
Embraco	SE6078GS	ICF-6CM14-EX29Z4	85	F6 06	F6 65	F6 65	F6 65
Embraco	SE6085GS	ICF-6CM14-EX33Z4	85	F6 06	F6 65	F6 65	F6 65
Embraco	SE6089GS	ICF-7CM14-EX34Z4	100	F7 55	F7 65	F7 65	F7 67
Embraco	SE2006GS	ICF-1CL11-E6.0Z4	15	F1 00	F1 30	F1 30	F1 30
Embraco	SE2008GS	ICF-1CL11-E7.0Z4	15	F1 00	F1 30	F1 30	F1 30
Embraco	SE2010GS	ICF-1CL11-E8.0Z4	20	F1 00	F1 30	F1 30	F1 30
Embraco	SE2014GS	ICF-3CL11-EX12Z4	28	F3 20	F3 20	F3 20	F3 24
Embraco	SE2017GS	ICF-3CL11-EX14Z4	28	F3 20	F3 20	F3 20	F3 24
Embraco	SE2020GS	ICF-3CL11-EX17Z4	37	F3 20	F3 20	F3 20	F3 24

Table 19: Silence Series (Embraco)

			900 Rpm				
Brand	Model	IBS Model	Condanser Surf. Area	Cabin	Oil Seperator	Suction Accumulator	Oil Sep.+ Suction Accu.
Embraco	SE6015GS	ICF-3CM11-E6.0Z6	28	F3 20	F3 20	F3 20	F3 24
Embraco	SE6018GS	ICF-3CM11-E7.0Z6	28	F3 20	F3 20	F3 20	F3 24
Embraco	SE6021GS	ICF-3CM11-E8.0Z6	28	F3 20	F3 20	F3 20	F3 24
Embraco	SE6030GS	ICF-4CM12-EX12Z6	44	F4 20	F4 20	F4 20	F4 33
Embraco	SE6036GS	ICF-4CM12-EX14Z6	44	F4 20	F4 20	F4 22	F4 33
Embraco	SE6043GS	ICF-4CM12-EX17Z6	57	F4 20	F4 20	F4 22	F4 33
Embraco	SE6053GS	ICF-5CM12-EX20Z6	83	F5 22	F5 34	F5 34	F5 34
Embraco	SE6056GS	ICF-5CM12-EX21Z6	83	F5 22	F5 34	F5 34	F5 34
Embraco	SE6067GS	ICF-6CM14-EX25Z6	85	F6 06	F6 65	F6 65	F6 65
Embraco	SE6078GS	ICF-7CM14-EX29Z6	100	F7 55	F7 65	F7 65	F7 67
Embraco	SE6085GS	ICF-7CM14-EX33Z6	100	F7 55	F7 65	F7 65	F7 67
Embraco	SE6089GS	ICF-7CM14-EX34Z6	133	F7 55	F7 65	F7 65	F7 67
Embraco	SE2006GS	ICF-1CL11-E6.0Z6	15	F1 00	F1 30	F1 30	F1 30
Embraco	SE2008GS	ICF-3CL11-E7.0Z6	28	F3 20	F3 20	F3 20	F3 24
Embraco	SE2010GS	ICF-3CL11-E8.0Z6	28	F3 20	F3 20	F3 20	F3 24
Embraco	SE2014GS	ICF-3CL11-EX12Z6	28	F3 20	F3 20	F3 20	F3 24
Embraco	SE2017GS	ICF-3CL11-EX14Z6	37	F3 20	F3 20	F3 20	F3 24
Embraco	SE2020GS	ICF-4CL12-EX17Z6	44	F4 20	F4 20	F4 20	F4 33

Outline Drawings

Figure 12: F1 00 Cabin

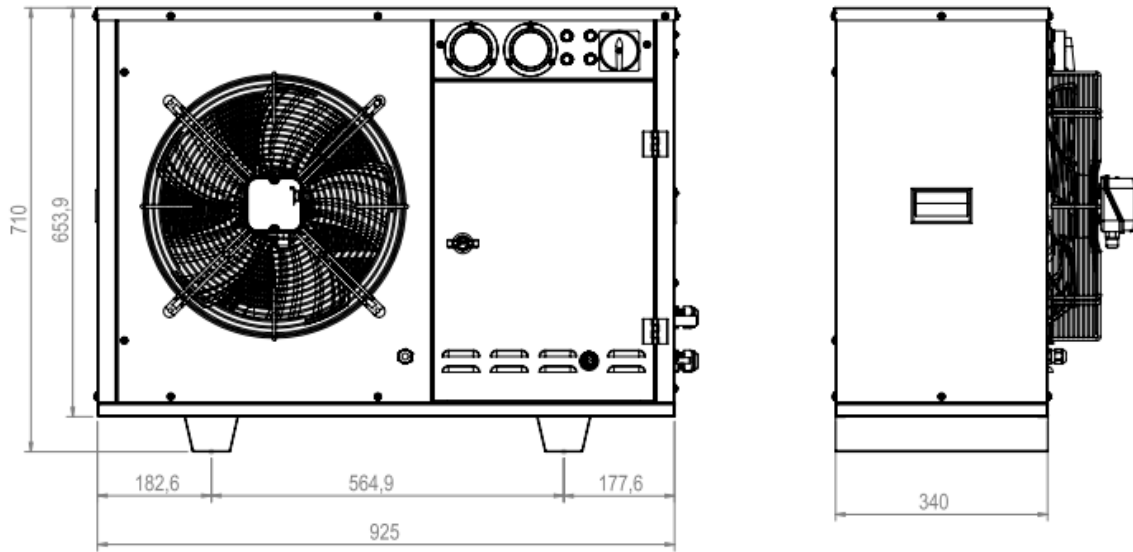

Figure 13: F1 10 Cabin

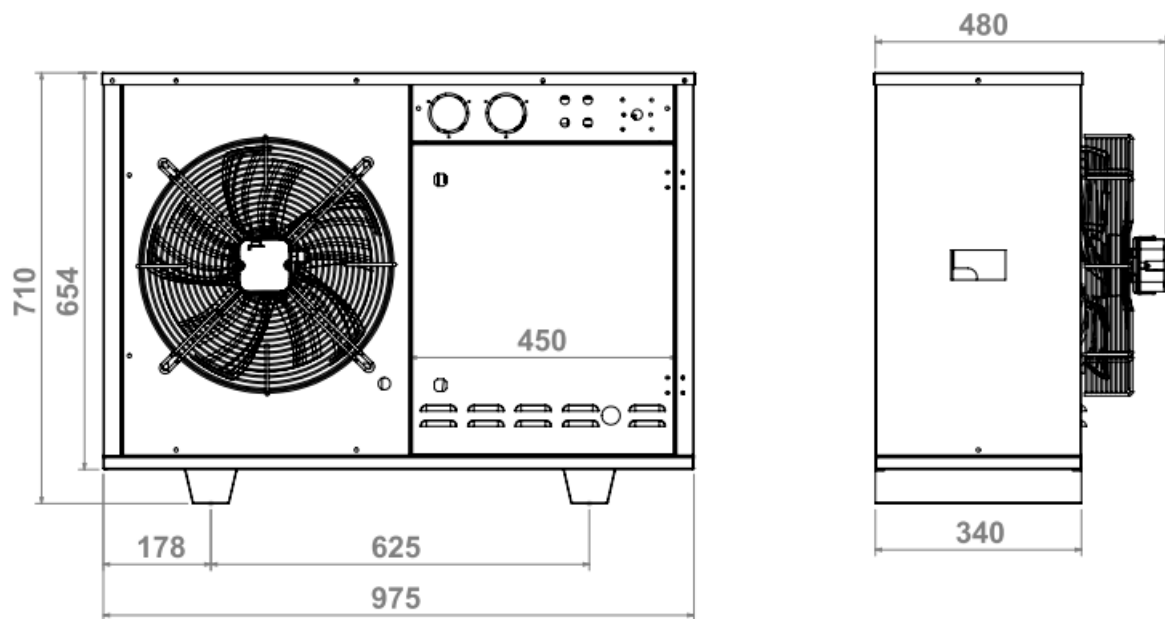

Figure 14: F1 30 Cabin

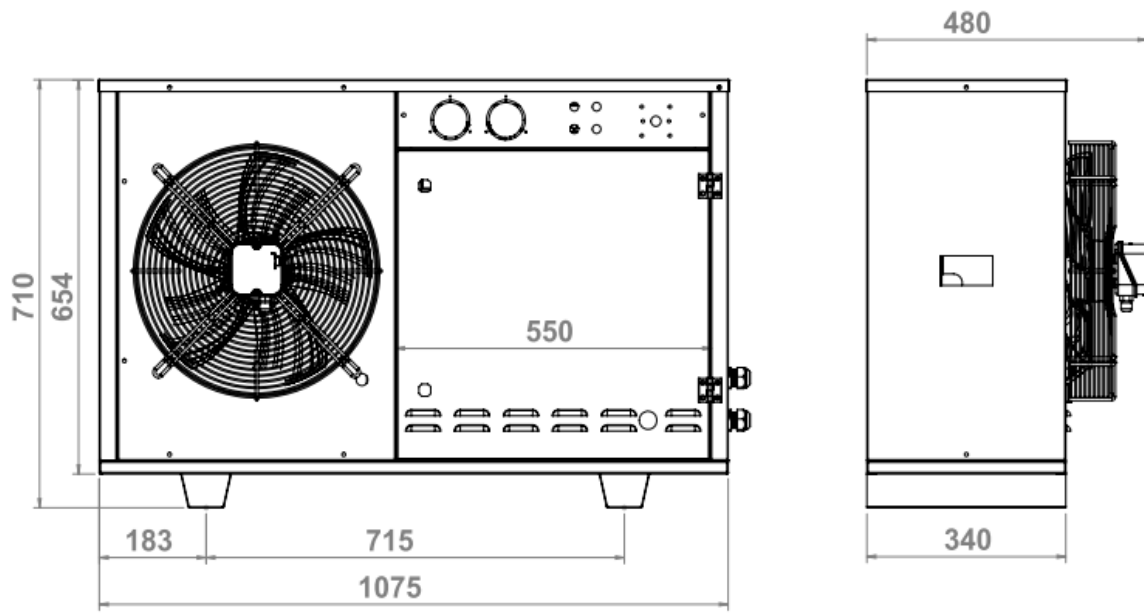

Figure 15: F3 20 Cabin

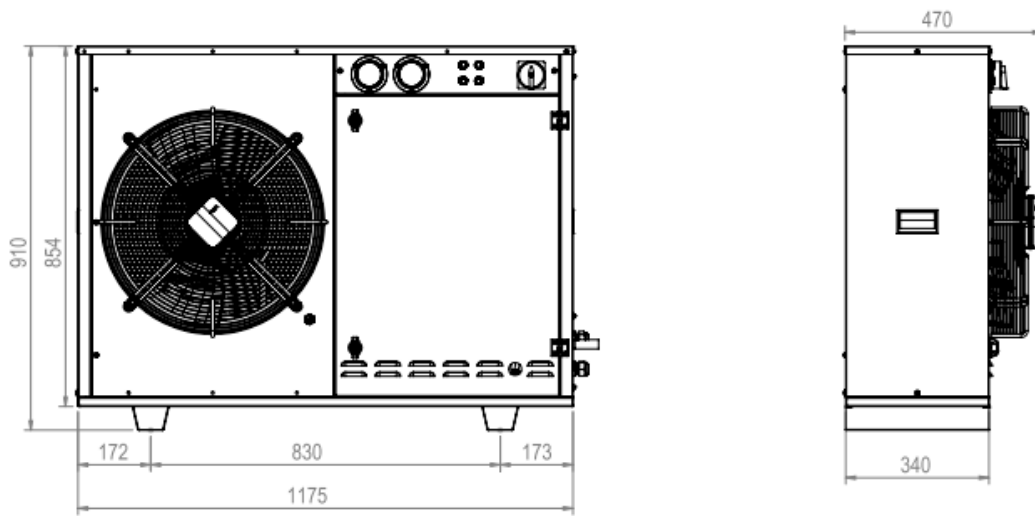

Figure 16: F3 24 Cabin

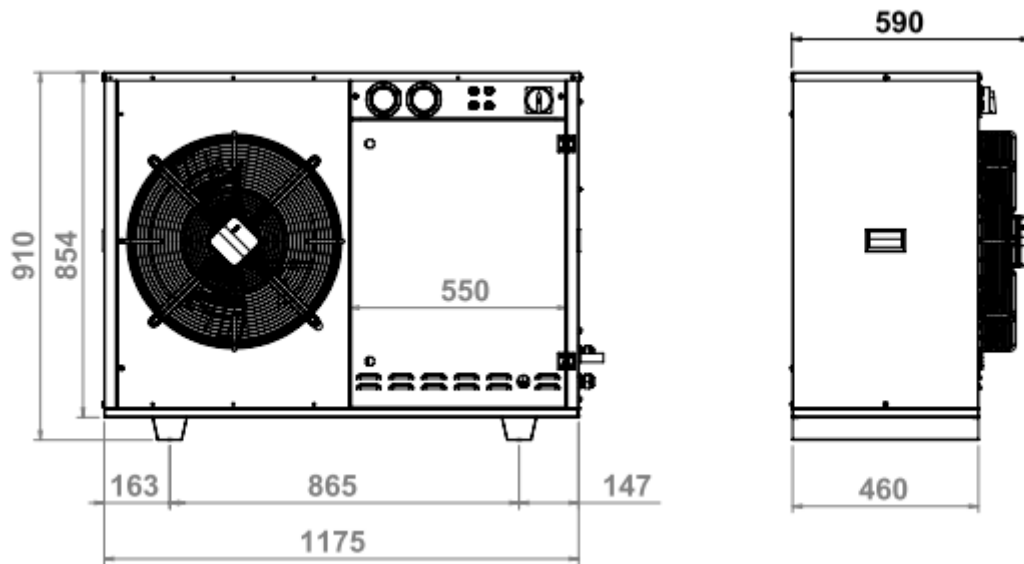

Figure 17: F3 44 Cabin

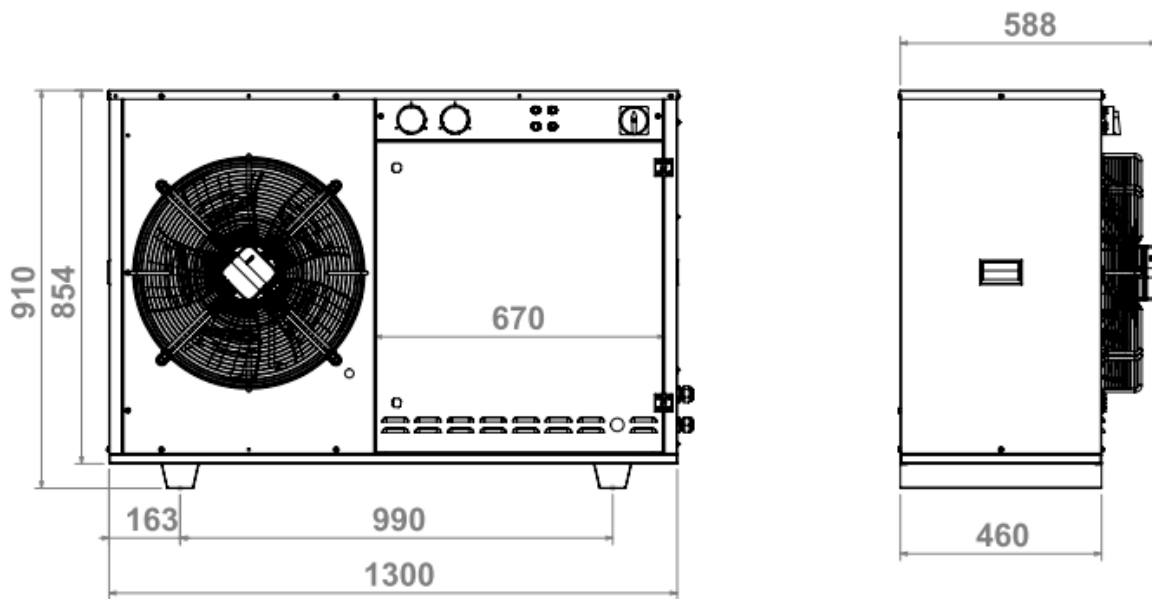

Figure 18: F4 20 Cabin

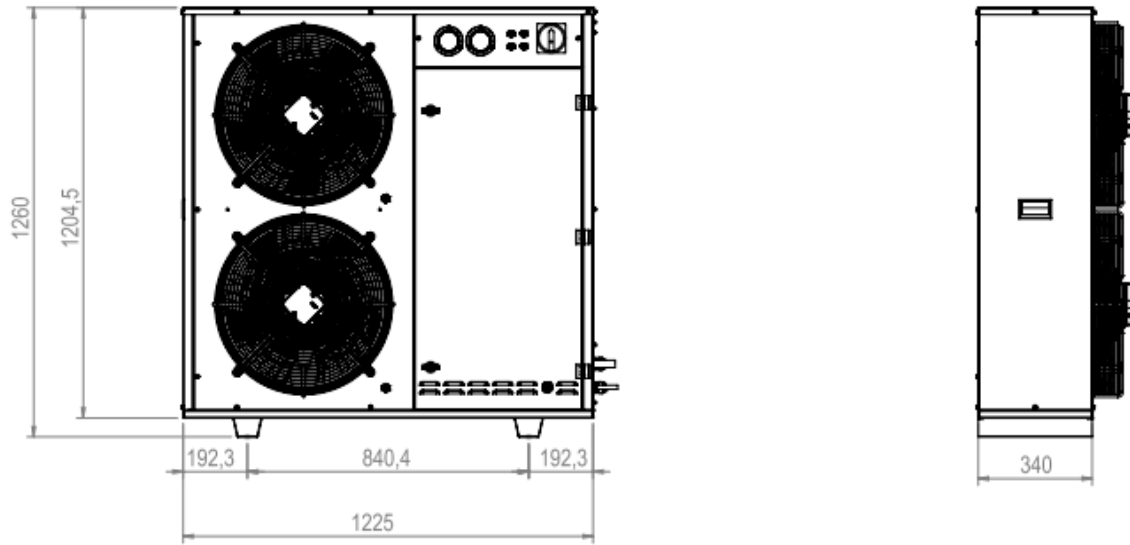

Figure 19: F4 22 Cabin

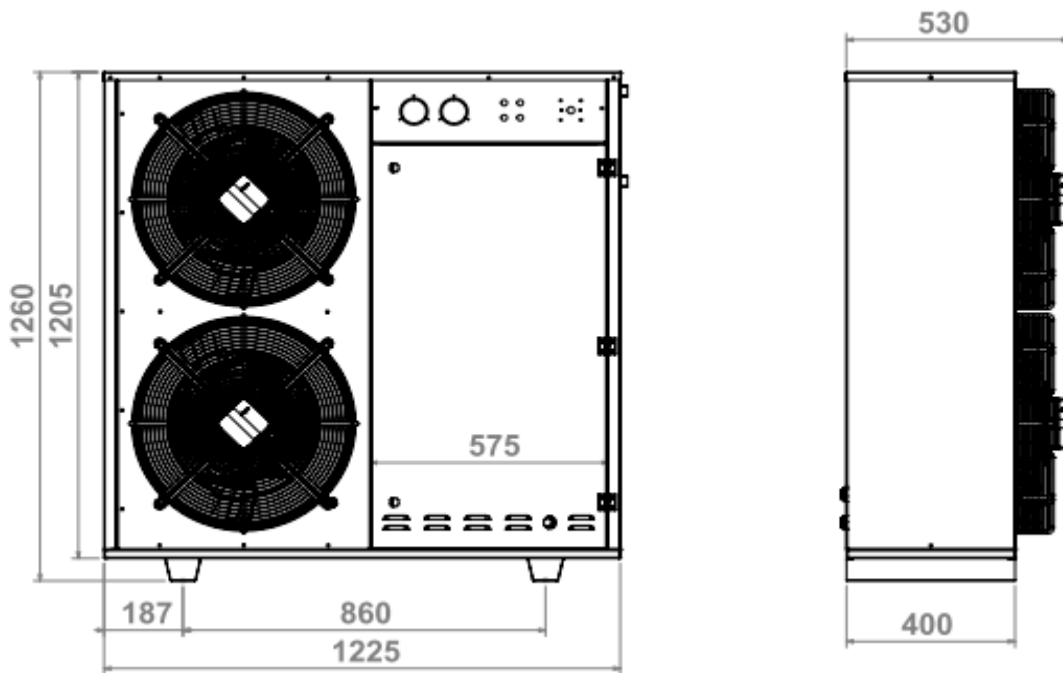

Figure 20: F4 33 Cabin

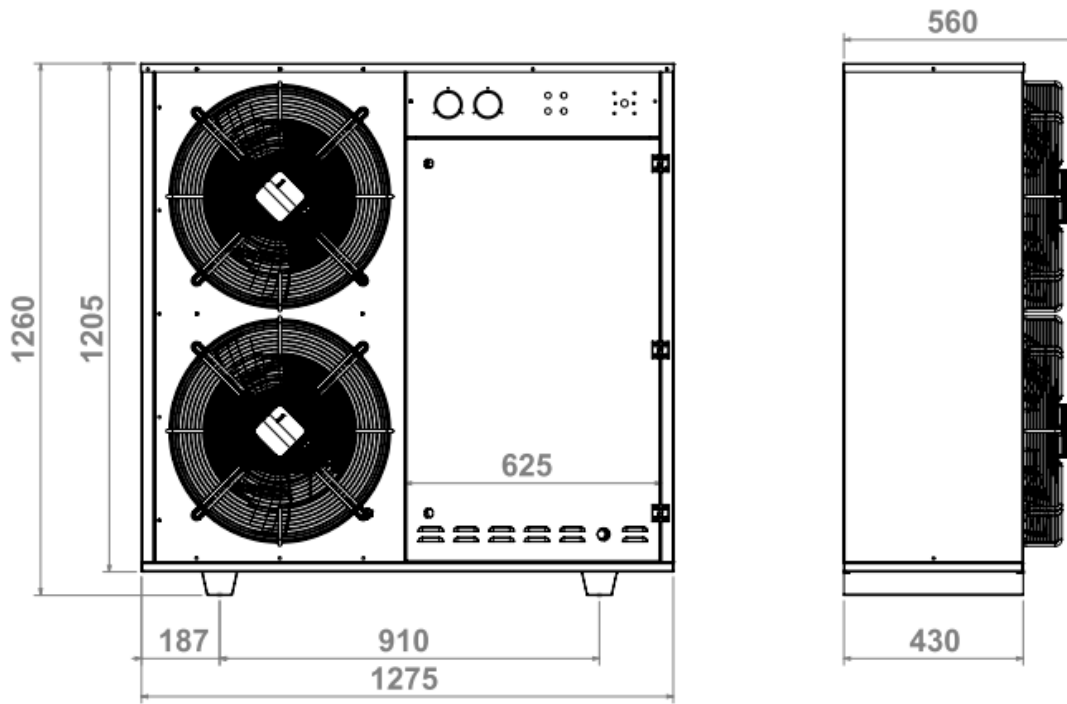

Figure 21: F4 34 Cabin

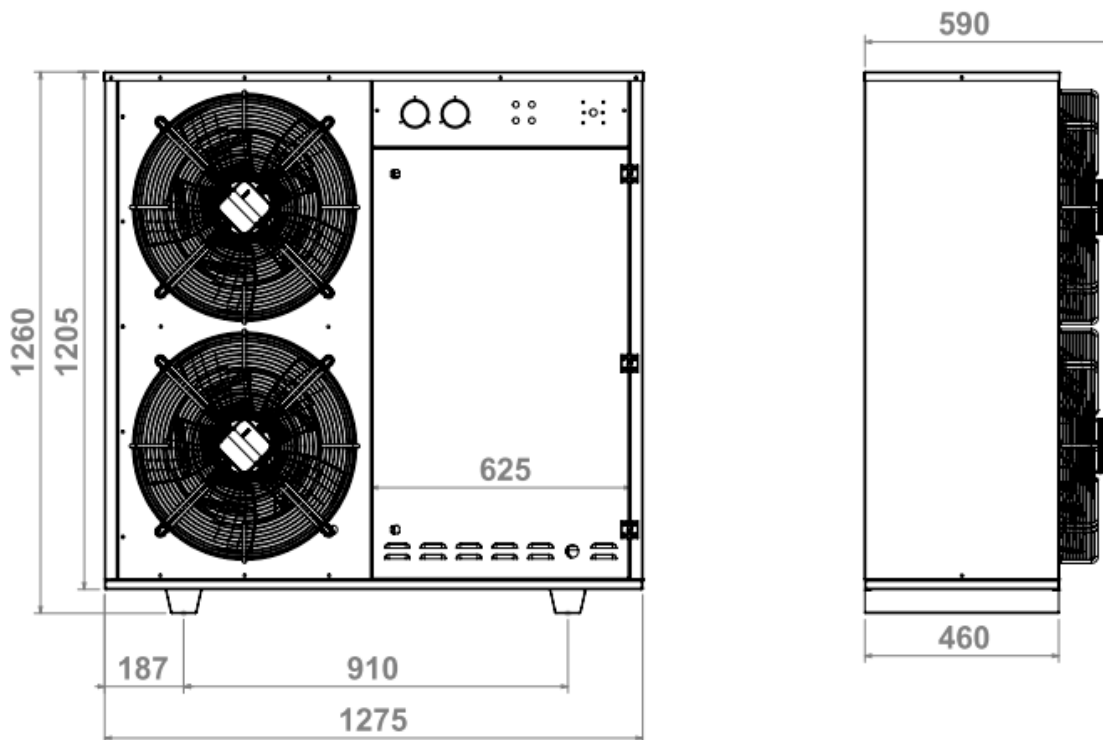

Figure 22: F4 54 Cabin

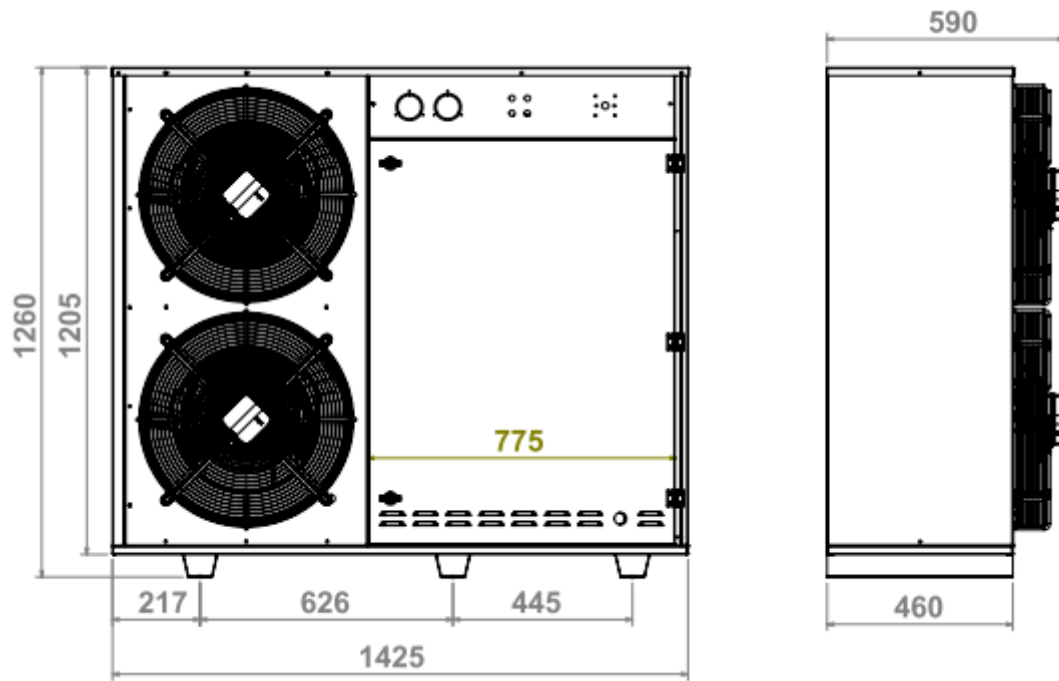

Figure 23: F5 22 Cabin

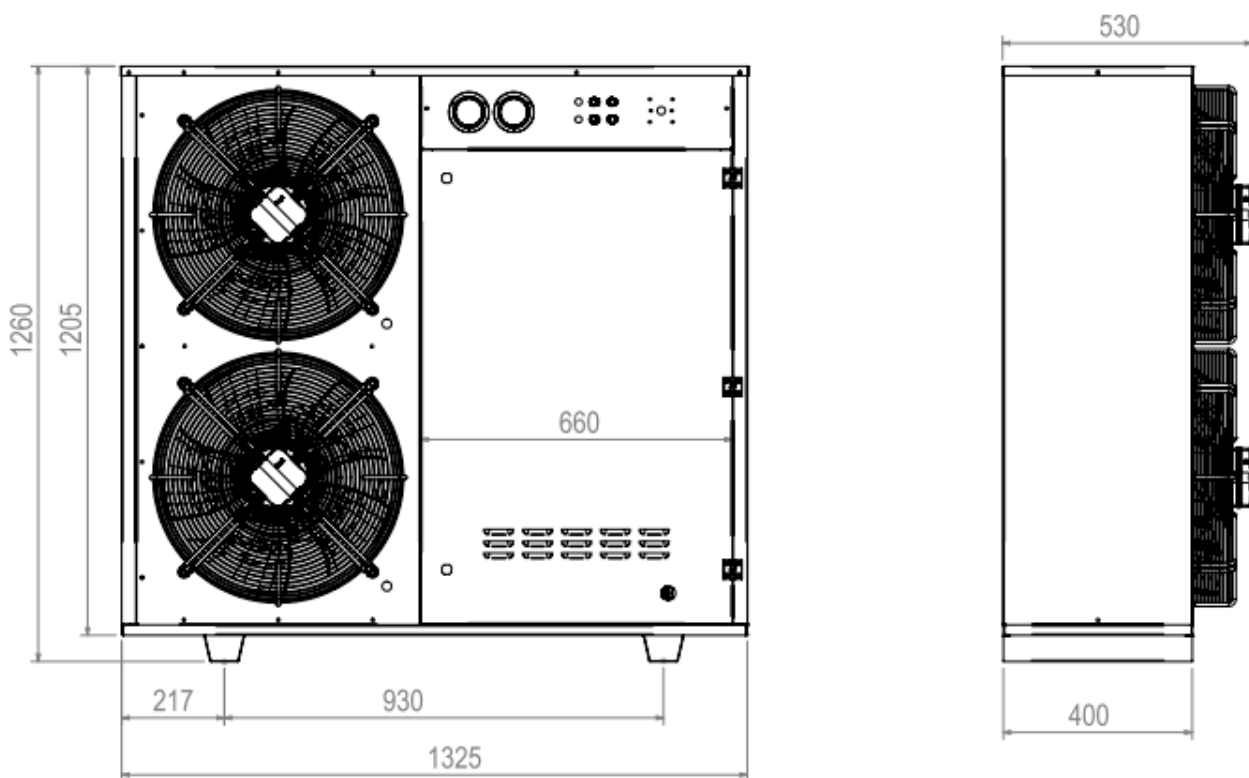

Figure 24: F5 34 Cabin

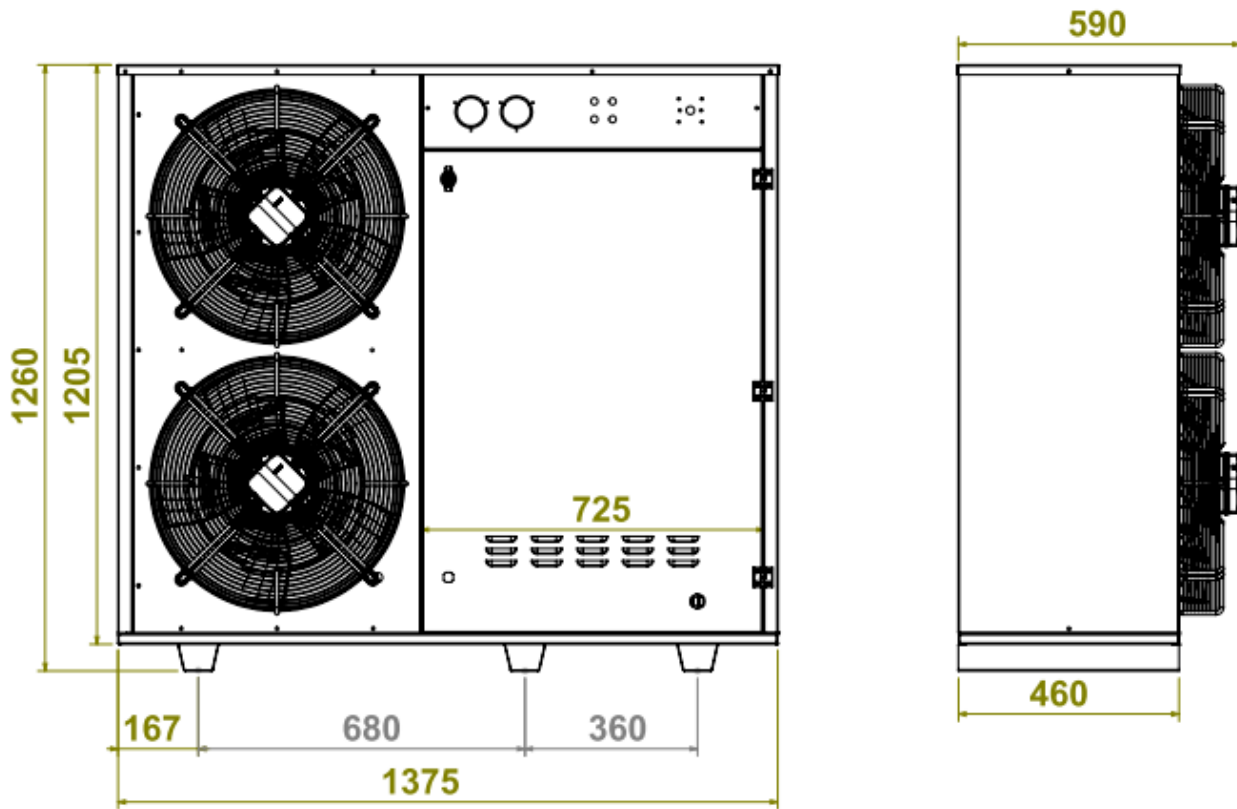

Figure 25: F5 54 Cabin

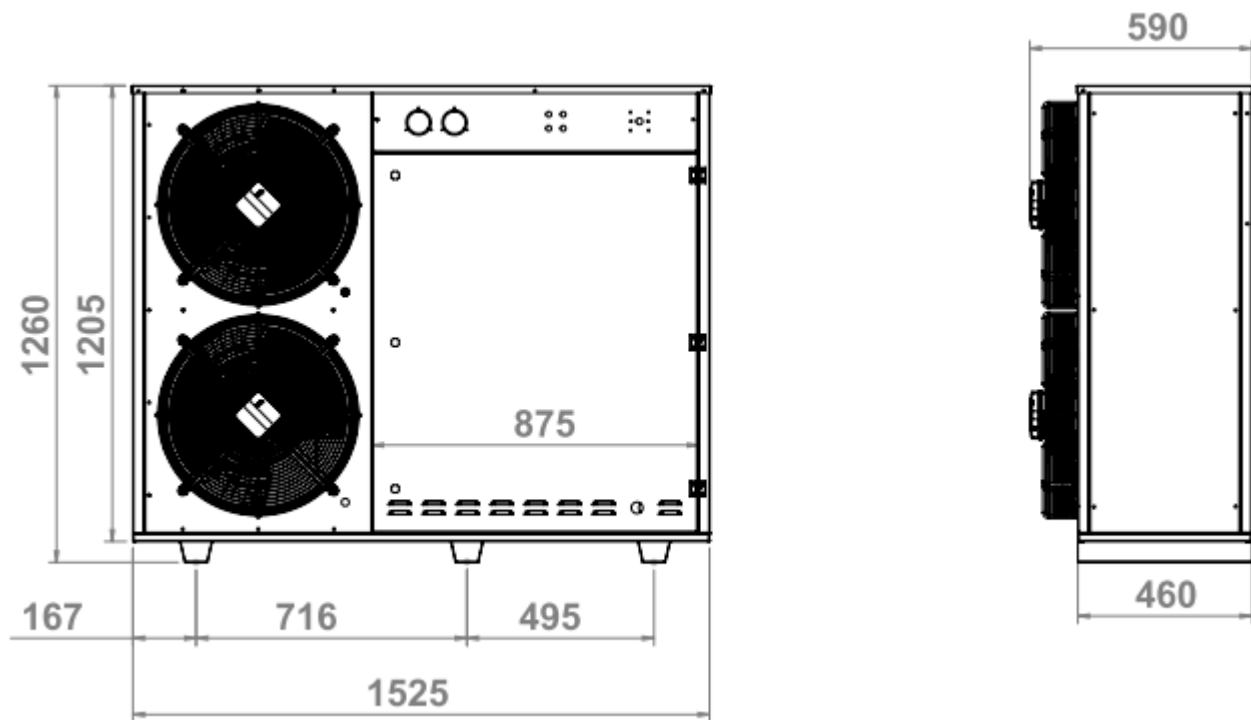

Figure 26: F6 06 Cabin

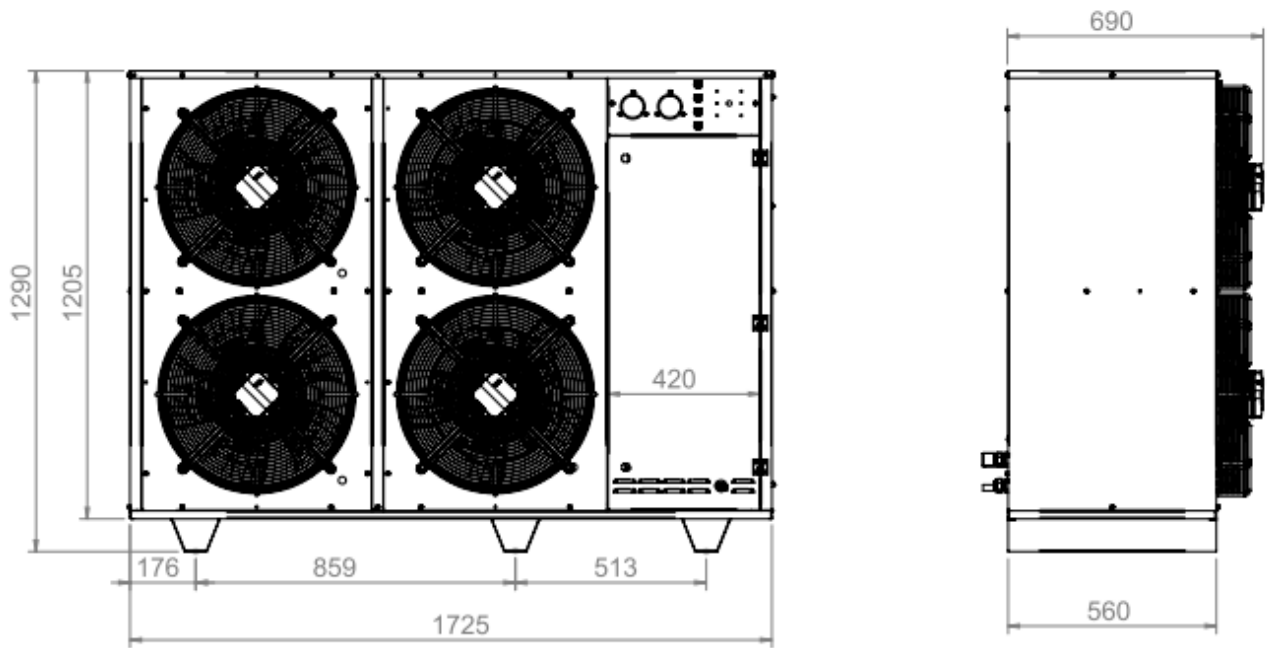

Figure 27: F6 65 Cabin

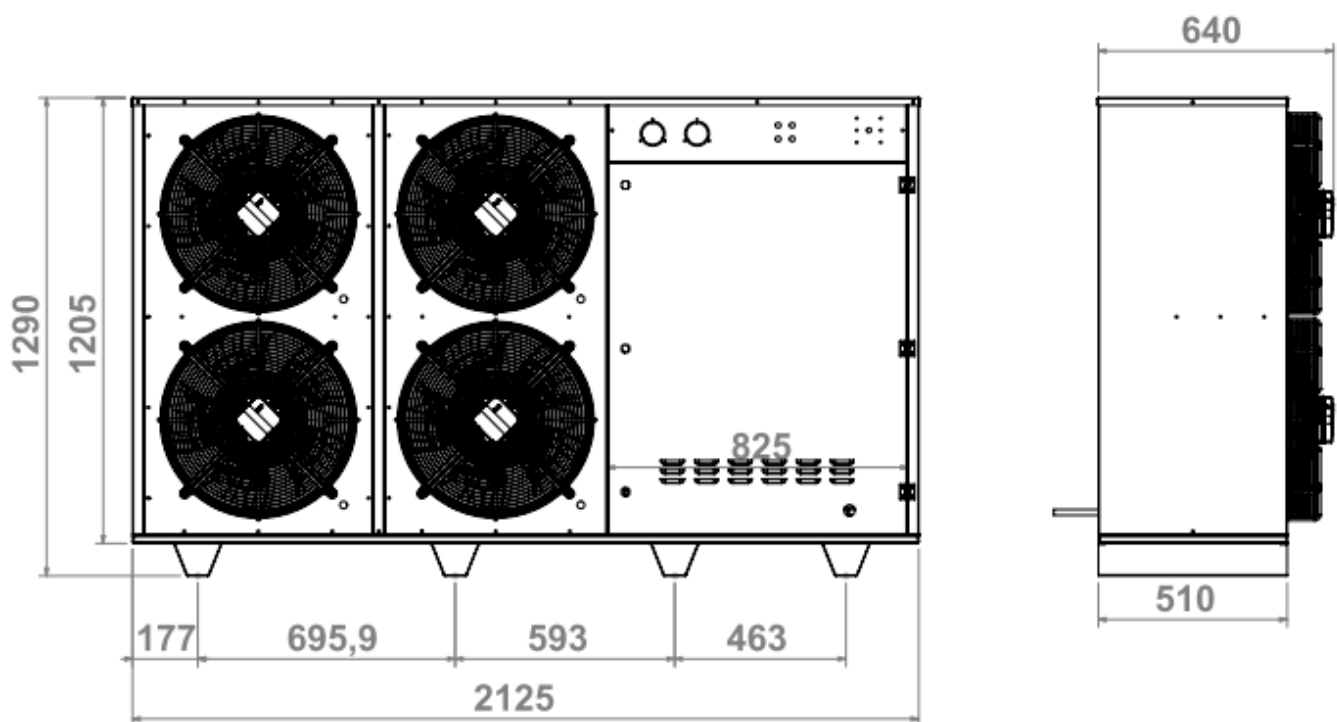

Figure 28: F7 15 Cabin

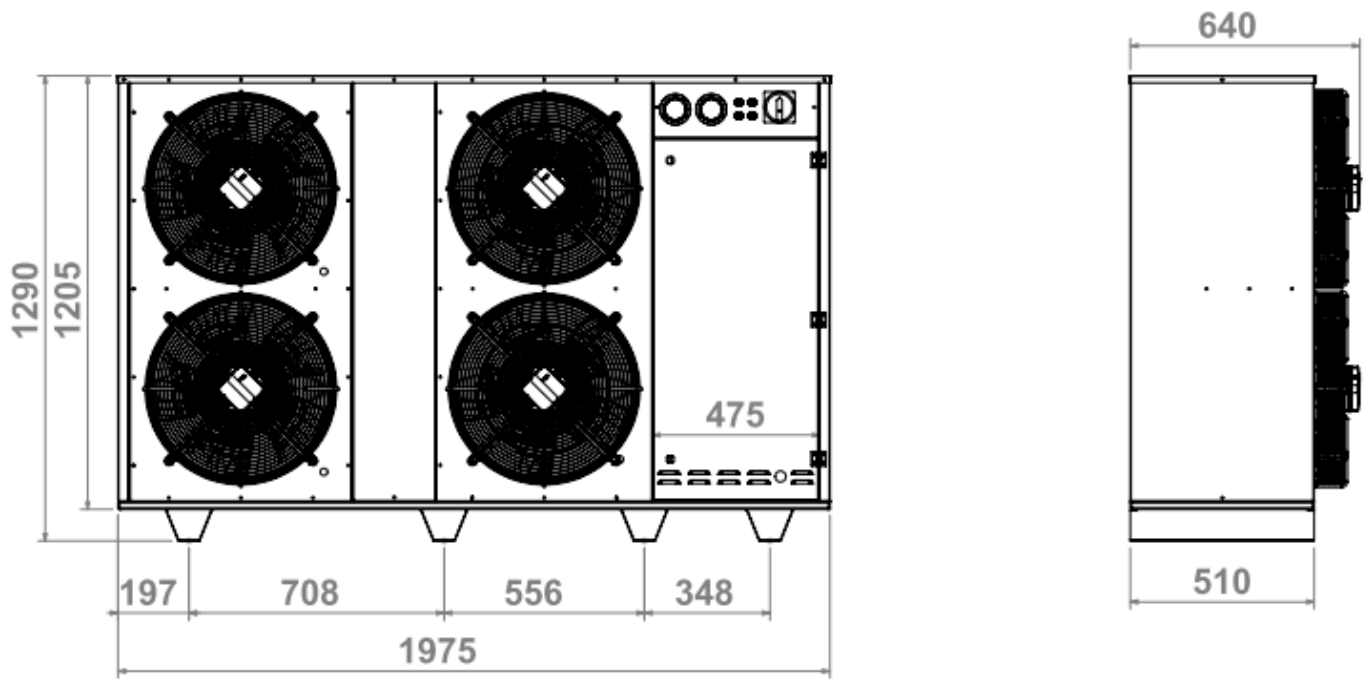
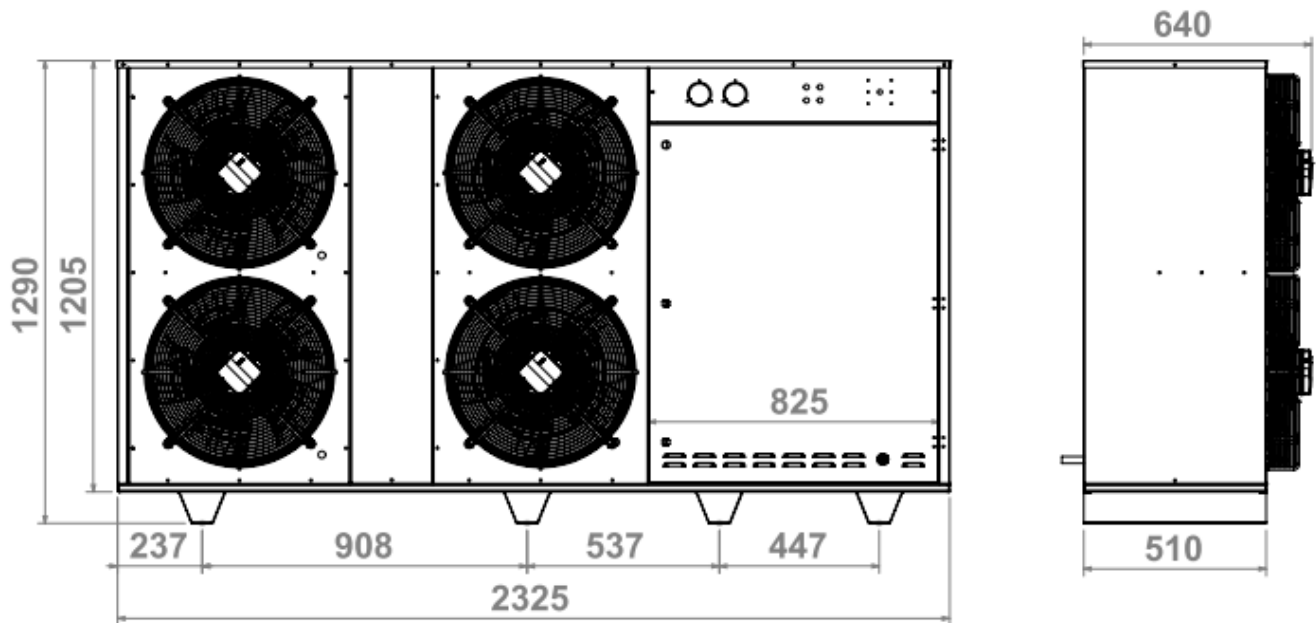

Figure 32: F7 65 Cabin



TROUBLE SHOOTING

You can find Trouble shooting table which includes Problems, Causes and Solutions. It's important to note that many problems require solutions beyond the user's capabilities. Such problems can be solved by authorized service personnel with good equipment. Try to solve the problems according to the instructions below. Remember that continuing to operate the unit without resolving the problems may lead to permanent damage in the future. If you cannot solve the problems yourself, please contact your nearest service provider.

PROBLEM	POSSIBLE CAUSE	CHECK	SOLUTIONS
COMPRESSOR			
Compressor will not starting	Power Supply	Phase(s) and neutral present?	Check/rectify
		Voltage within tolerance?	Check/rectify
		Is isolator switched on?	If not - switch on
	Compressor contactor not pulled in (where fitted)	Is there correct voltage to contactor coil?	If yes - coil faulty. Replace contactor/coil If no - check for break in control circuit or blown control fuse.
		Has a safety switch tripped out?	Check cause and reset
	Compressor contactor pulled in but compressor not running	Is voltage being switched across contactor?	If yes - check voltage at compressor terminals and compressor wiring If no - Replace the faulty contactor
		Safety switch tripped (LP, HP, Overload)	Low and High pressure conditions and current draw on overload. Check settings of safety switches are correct.
	Compressor internal overload tripped	Is the correct voltage at compressor terminals?	Compressor has overheated -allow time for reset (up to 3 hours) and rectify cause
	Control fuse blown in panel		Replace fuse and test - rectify fault
	Starting kit faulty (single phase units only)	Check relay operation and contacts and inspect start/run capacitors	Replace as necessary
	Motor windings faulty	Check resistances of windings against manufacturer values	Windings that show open circuit could be due to internal overload trip. Wait for reset and recheck. If continually open circuit - motor faulty. Replace compressor.
	Compressor seized	Does compressor attempt to start but does not run correctly (makes humming sound)? Are amps equivalent to LRC rating?	If all electrical checks on components as above are OK -Change compressor
Compressor runs but no effect on suction/discharge pressures	Mechanical failure	Are compressor motor amps lower than expected? If so - potentially valve reeds damaged or other internal wear/damage	Try pump test on compressor. If test fails - replace compressor.
	(For three-phase scroll compressors only)	The compressor may be running backwards - the compressor will also be noisier than normal	Swap any two of the incoming phases to the isolator switch and recheck.

Compressor starts and stops too quickly	Operating on safety switches	Check LP & HP settings - is the LP differential too small or the HP setting too low?	Check and adjust switch settings. Check all valves are in open position
	Refrigerant levels	Is there too little refrigerant in the system causing rapid LP tripping or too much refrigerant in the system causing HP tripping?	Check refrigerant level and adjust accordingly
	Faulty contactor (if fitted)	Are the contacts chattering on the contactor?	Contacts may be dirty or worn. Check and replace contactor as necessary
	Loose / broken wiring connection		Make sure all electrical connections are sound
Compressor is noisy	Vibration	Rubber feet mountings worn or bolts are loose/missing	Replace mountings and tighten/replace bolts as necessary
	Lack of oil	Check oil sight glass to see if level below recommended level	Top up with oil as necessary
	Too much oil	Check oil sight glass to see if level above recommended level	Remove oil overcharge
	Liquid refrigerant	Does compressor 'knock' when starting up or running? Liquid refrigerant may be present in oil and compression chambers	Identify cause of liquid return to compressor and rectify
	Overloaded	Are suction and discharge pressures too high? There may be too much load on the compressor.	Identify cause of increased load and rectify
	High discharge pressure	Blocked condenser / faulty condenser fan	Check and rectify
		Refrigerant overcharge	Check and rectify
	Non-condensable in system	Reclaim refrigerant, evacuate & recharge	
Internal wear / damage	Noise is always present even if all operating conditions are, OK?	Replace compressor	
Compressor body too hot	System load too high	Are suction and discharge pressures high?	Reduce load at evaporator
	High discharge pressure	Blocked condenser / faulty condenser fan	Check and rectify
	Lack of compressor cooling	Suction superheat too high	Check refrigerant charge correct
			Check TEV superheat setting correct
			Is suction line correctly insulated?
	Compressor starting too frequently	Are controls set correctly - is the differential on thermostat or LP switch too small?	Check and adjust
Is the liquid line solenoid valve allowing refrigerant to pass when closed?		Check valve and clean seat or replace as necessary if damaged	
Discharge gas bleeding into suction side	Does suction pressure rise abnormally when compressor stops or compressor fails to pump down correctly?	Compressor valve reeds may be damaged - replace compressor	
SYSTEM			
Insufficient cooling	Lack of refrigerant	Is sight glass flashing continuously?	Leak test system and top up with refrigerant
	Condenser coil dirty	Visual check of coil condition	Clean condenser coil
	Lack of ventilation to unit	Any obstructions around unit?	Clear same to ensure good ventilation
	Compressor not pumping efficiently	Carry out pump test on compressor	Replace compressor if fails pump test
	System settings	Controls (inc thermostat) set correctly?	Adjust as necessary
		T.E.V. Superheat	Adjust as necessary
	Service valves do not open correctly	Are valves fully open?	Adjust as necessary
	Restriction in piping/component	Is the filter drier blocked? Sweating/frosting on outlet of drier indicates a blockage	Replace filter drier
Damage to piping		Replace piping as required	

CONDENSER FAN			
Condenser fan will not run	Power supply	See compressor will not start section	See compressor will not start section
	Compressor contactor not pulled in	See compressor will not start section	See compressor will not start section
	Compressor contactor pulled in	Is voltage being switched across contactor?	If yes - check voltage to FSC and to fan motor. If correct voltage present at motor - fan faulty. Replace fan
			If no. Replace faulty contactor
	Being controlled by FSC (if fitted)	Is system operating pressure below FSC setting?	If yes - all OK (check fan operates when pressure rises)
	Fan capacitor fault	Check visual condition of capacitor and check capacitance reading with capacitor meter.	Replace capacitor if required
Motor fault	If FSC fitted - bypass FSC to test motor. If motor still does not run -motor is faulty	Replace motor	
Condenser fan runs but only slowly	Is fan being controlled by FSC?	Is head pressure under control (~14/15 bar on R448A/449A) and fan speed increases as head pressure rises?	All OK
		Is head pressure above 16 bar (R448/449A)?	Check setting of FSC. Adjust if necessary.
	FSC faulty	If fan runs slowly even after adjusting FSC with head pressure rising - FSC may be faulty	Change FSC

CERTIFICATES

2006/42/EC Machinery Directive



CERTIFICATE

Certificate - No.: 23-IS-2138-TAT-24-MAD-0313

Applicant	: IBS SOĞUTMA ISITMA HAVALANDIRMA TAAHHÜT SAN. VE TIC. A.Ş. Organize Sanayi Bölgesi 2. Cadde No:39 Y.Dudullu/İSTANBUL
Product	: Condensing Units, Evaporators
Type(s)	: # Split Type, Industrial Type, Open Type, Standard Type, Ceiling Type, Blast Freezer Type #
Model(s)	: # ICF Series, ICE Series, ICC Series, ICO Series, ICV Series, ICB Series, ICD Series, ICS Series, ICT Series #
Standard(s) / Certification Basis	: 2006/42/EC Machinery Directive EN ISO 12100:2010 EN 60204-1:2018

This Certificate is issued on a voluntary basis according to Machinery Directive 2006/42/EC. It conforms that the listed equipment complies with the essential safety requirements of the directive. It refers only to the sample and its technical file submitted for conformity assessment.

Reference Inspection Report No : 23-IS-2138-UDR-01

First Issue Date : 06.05.2024

Date of Revision : 06.01.2026

Expiry Date : 05.05.2029

The certificate is valid as long as the standards and legislation are current and annual audit is performed with satisfactory results.

For and behalf of
TÜV AUSTRIA TÜRK Belgelendirme
Eğitim ve Gözetim Hizmetleri Ltd.Şti.
Emrah Ümit-ŞİRANLI

After preparation of the necessary technical documentation as well as the declaration of conformity the required CE marking can be affixed on the product. Other relevant directives have to be observed.

This Certificate has been granted to the applicant based on the results of testing performed by the applicant/manufacturer or an accepted laboratory and the consequent review of the test report by TÜV AUSTRIA TÜRK. Revisions to the referenced certification basis or any change of the design, materials, components or processing may require the repetition of all or some of the qualification tests in order for the test report and therefore this associated certificate to remain valid.

ZERTIFIKAT | CERTIFICATE | CERTIFICAT | CERTIFICADO | СЕРТИФИКАТ | 證書 | 인증서 | شهادة

GRT-AUD-101 Certificate of
Conformity_MD
Revision: 01 Date: 09.03.2020
Page 1/1

TÜV AUSTRIA TÜRK
Except duplication only with permission of TÜV AUSTRIA TÜRK.
All testing inspection and surveillance activities were carried out in accordance with the GM
system of
TÜV AUSTRIA TÜRK

Çamlik Mah. İksal Cad.
Dinc Sk. No:28 PK:34774
Ümraniye / İSTANBUL
E-mail: info@turkey.tuv.at

Unauthenticated Download Date: 06/05/2024 10:00:00 AM



SERTİFİKA CERTIFICATE OF REGISTRATION

Bu sertifika aşağıdaki kuruluşa
This certificate has been awarded to the company

IBS ISITMA SOĞUTMA HAVALANDIRMA TAAHHÜT SANAYİ VE TİCARET ANONİM ŞİRKETİ

Dudullu Organize Sanayi Bölgesi 2. Cadde No:39 Y.Dudullu
34775 Ümraniye, İSTANBUL

Uygulanmakta olan Kalite yönetim sisteminin
To certify that the implemented Quality management system complies with

ISO 9001:2015

Standardına uygunluğunu belgelendirmek amacı ile aşağıdaki kapsamda verilmiştir.
For the activities described below

ISITMA, SOĞUTMA, HAVALANDIRMA SİSTEMLERİNİN TASARIM, ÜRETİM, SATIŞ, TAAHHÜT, SERVİS VE BAKIMI

**DESIGN, MANUFACTURING, TRADING, CONTRACTING, SERVICE AND
MAINTENANCE OF HEATING, COOLING AND VENTILATION SYSTEMS**

Sertifika No / Certificate No : 1840214
İlk Belgelendirme Tarihi / Initial Certification Date : 22.03.2018
Sertifika Tarihi / Date of Certificate : 25.05.2025
** Geçerlilik Tarihi / Validity Date : 21.03.2026
3 Yıllık Çevrim Bitiş Tarihi / 3 Year Cycle End Date : 21.03.2027

E.Ö.Ö.

İstanbul, 25.05.2025 (Rev.07)

İşbu sertifika, Naviga'nın prosedür, talimatlarına ve yukarıdaki standardın gerekliliklerine ve düzenli olarak yapılacak gözetim denetimlerinin başarı ile tamamlanmasına bağlı olarak, yukarıdaki adres ve kapsam dahilinde geçerlidir.
****Bir sonraki denetimin başarılı bir şekilde tamamlanması durumunda, sertifika yenilenecektir.**
Bu sertifikanın geçerliliği, TÜRKAK veritabanına başlanıp sağlanan QR kodu ile veya QR kodu altındaki TBDS sertifika numarası ile <https://tbds.turkak.org.tr> adresinden doğrulanabilir.

This certificate is valid for above address(es) and scope upon compliance with Naviga procedure(s), instruction(s) and the above mentioned standard and successful completion of regular surveillance audits.

****Upon successful completion of the next audit, the certificate will be renewed.**

The validity of this certificate can be checked through QR code by TÜRKAK database or TBDS certificate no. under QR code on <https://tbds.turkak.org.tr> webpage.

NAVIGA ULUSLARARASI BELGELENDİRME VE EĞİTİM HİZMETLERİ LTD. ŞTİ.
Yenibosna Merkez Mah. Çınar Cad. Güneşli Matbaa Sitesi No:4 İç Kapı No:213 Bahçelievler/İSTANBUL
Tel: 0212 482 9656 Fax: 0212 482 9424 www.navigald.com - info@navigald.com



IAF SEARCH



TÜRKAK BDS NO
YS-0067-7B19



Kalite Yönetim Sistemi
TÜRKAK BDS NO YS-0067-7B19
AB 0028 YS

FR.069/Rev.05/02.01.2025



EU-Baumusterprüfbescheinigung EU-type examination certificate

Modul B: EU-Baumusterprüfung (Baumuster) nach Richtlinie 2014/68/EU
Module B: EU-type examination - production type according to Directive 2014/68/EU

Bescheinigung Nr.: 2024 – TATR - 263-22-IS-1995
Certificate No.:

Hersteller / manufacturer:

IBS Isıtma Soğutma Havalandırma Taahhüt
Sanayi ve Tic. A. Ş Organize Sanayi Bölgesi 2.Cadde. No:39
Y.Dudullu/Istanbul / TÜRKIYE

Hiermit wird bescheinigt, dass die Ergebnisse der an dem unten genannten Druckgerät vorgenommenen Prüfungen die Anforderungen der Richtlinie 2014/68/EU erfüllen. Die Zertifizierungsentscheidung wurde vom Unterzeichner auf Basis einer unparteilichen Bewertung der Evaluierung getroffen.
This is to certify that the results of the examination of the pressure equipment mentioned below meet the requirements of the directive 2014/68/EU. The certification decision was made by the signee on the basis of an impartial review of the evaluation.

Diese Bescheinigung ist gültig bis zum 18.3.2034
This certificate is valid through 18 Mar 2034

Objekt:
Object: Baugruppe / assembly

Benennung:
Description: MANUFACTURING AND SIMPLE ASSEMBLIES OF COLLING UNIT
ICF-ICE SM GRUP & IMC VDL1Y & ISS-SS01 GRUP & KF GRUP
PACK+SCROLL GRUP&PACK+SM GRUP&ICF HM-CM GRUP

Inspektionsbericht Nr. :
Inspection report no : 22-IS-1995-PED-24-IR-01

ISTANBUL
Ort / place: 18.03.2024
Datum / date:

HAKIM ÖZLÜK
Notifizierte Stelle / notified body 0408
TÜV AUSTRIA GMBH



CERTIFICATE

Certificate registration number: ZSTS/SWZE/6141

The notified body
TÜV AUSTRIA GMBH (identification number 0408)
certifies, that the manufacturer

IBS Isıtma Soğutma Havalandırma Taahhüt Sanayi ve Tic. A. Ş
Organize Sanayi Bölgesi 2.Cadde. No:39 Y.Dudullu/İstanbul / TÜRKİYE

operates a quality assurance system for design, manufacture, final inspection and testing according to Annex III of the Pressure Equipment Directive 2014/68/EU which is subject to surveillance by TÜV AUSTRIA GMBH and is therefore authorized to apply the following conformity assessment procedures according Pressure Equipment Directive 2014/68/EU:

Modules E, E1, D and D1

Scope: **MANUFACTURING AND SIMPLE ASSEMBLIES OF COLLING UNIT**
ICF-ICE SM GRUP & IMC VDL1Y & ISS-SS01 GRUP & KF GRUP PACK+SCROLL
GRUP&PACK+SM GRUP&ICF HM-CM GRUP

Based on our audit carried out on April 24, 2024 in accordance with Annex III of the Pressure Equipment Directive 2014/68/EU we certify compliance with the requirements.

Results of the audit are recorded in the audit report
22-IS-1995-2024-PED-Modul D-009 dated April 24, 2024.

Pressure equipment and assemblies within the scope of this certificate shall carry the marking as illustrated:

CE 0408

This certificate is valid from April 24, 2024 to April 23, 2027 provided that the terms and conditions of the agreement with the notified body are met.

Vienna, 24.04.2024



Plunwarz

DI Martin Schwarz
Notified Body 0408
TÜV AUSTRIA GMBH



ZERTIFIKAT | CERTIFICATE | CERTIFICAT | CERTIFICADO | СЕРТИФИКАТ | شهادة | 证书 | 인증서





Scan the QR code to view the Operating Manual on your tablet, mobile device, PC or laptop.

CONTACT



Dudullu Organize Sanayi Bolgesi,
2.Cadde No:39, 34776, Umraniye
Istanbul/ Turkiye



info@ibs.com.tr



[+90 \(216\) 466 04 06](tel:+90(216)4660406)

